



A U S T R A L I A N M E A T P R O C E S S O R C O R P O R A T I O N

Appendix 2: Hazard and Risk Assessment - Biogas Systems

Disclaimer:

The information contained within this publication has been prepared by a third party commissioned by Australian Meat Processor Corporation Ltd (AMPC). It does not necessarily reflect the opinion or position of AMPC. Care is taken to ensure the accuracy of the information contained in this publication. However, AMPC cannot accept responsibility for the accuracy or completeness of the information or opinions contained in this publication, nor does it endorse or adopt the information contained in this report.

No part of this work may be reproduced, copied, published, communicated or adapted in any form or by any means (electronic or otherwise) without the express written permission of Australian Meat Processor Corporation Ltd. All rights are expressly reserved. Requests for further authorisation should be directed to the Chief Executive Officer, AMPC, Suite 1, Level 5, 110 Walker Street Sydney NSW.

Table of Contents

Executive Summary	5
1 Introduction	7
1.1 Objectives of the Study	7
1.2 Description of background issues	7
2 Description of bio-gas facilities	8
2.1 Typical bio-gas generation facilities	8
2.2 Safety systems	8
3 Hazard identification and qualitative risk estimation	10
3.1 Hazards	10
3.2 Past incidents and accidents	10
3.3 Risk ranking and qualitative estimation	10
3.4 Major accident events to be considered	20
4 Consequence analysis of events	21
4.1 Analysis of consequences from key events	22
4.1.1 Fire radiation from flammable releases: underlying assumptions	22
4.2 Event consequence modelling	23
4.3 Impact analysis for Covered Anaerobic Lagoon events	23
4.4 Impact analysis for biogas transmission events	27
4.5 Impact analysis for biogas utility generation	29
4.6 Impact of hydrogen sulphide within bio-gas releases	31
5 Qualitative Risk Analysis and Assessment	34
5.1 Overview	34
5.2 Assessment of the risks	35
5.3 Semi-quantitative risks	35
5.4 Hydrogen sulphide impact risks	36
5.4.1 Fatality levels	366
5.4.2 Emergency response levels	37
6 References	40
Appendices	

Tables

Table 1 Qualitative risk matrix	12
Table 2 Influent feed system	15
Table 3 Covered anaerobic lagoons (CALs)	16
Table 4 Bio-gas transfer systems	18
Table 5 Bio-gas utility generation system	19
Table 6 CAL cover releases: effect distances	25
Table 7 Bio-gas releases from gas transmission: effect distances	27
Table 8 Thermal radiation estimates for bio-gas jet fires	28
Table 9 H ₂ S impacts from CAL releases	32
Table 10 H ₂ S impacts from bio-gas transmission releases	33
Table 11 Risk criteria for location specific individual fatality risks	35
Table 12 Risk Criteria - Injury Levels	35
Table 13 1% fatality concentration for different exposure times to H ₂ S	37
Table 14 Acute Exposure Guideline Levels for Hydrogen Sulphide	38

Figures

Figure 1 Generalised bio-gas system Piping and Instrumentation Diagram (P&ID)	9
Figure 2 Location of key events for biogas hazards and risks (CAL, BGT and UTIL)	22
Figure 3 Overpressure from Genset building gas explosion	30

Images

Image 1: Case 1, 50Pa.g, 1000mm aperture, 30°, D4, LFL	41
Image 2 Case 1, 50Pa.g, 1000mm aperture, 30°, D4, half LFL	41
Image 3 Case 2, 100Pa.g, 1000mm aperture, 30°, D4, LFL	42
Image 4 Case 2, 100Pa.g, 1000mm aperture, 30°, D4, half LFL	42
Image 5 Case 3, 100Pa.g, 1000mm aperture, 30°, B2, LFL	43
Image 6 Case 3, 100Pa.g, 1000mm aperture, 30°, B2, half LFL	43
Image 7 Case 4, 200Pa.g, 1000mm aperture, 15°, D4, LFL (Rivalea test)	44
Image 8 Case 4, 200Pa.g, 1000mm aperture, 15°, D4, half LFL (Rivalea test)	44
Image 9 Case 4, 200Pa.g, 1000mm aperture, 0°, D4, LFL (Rivalea test)	45

Image 10 Case 4, 200Pa.g, 1000mm aperture, 0°, D4, half LFL (Rivalea test)	45
Image 11 Case 5, 50Pa.g, 200mm aperture, 90°, D4, LFL	46
Image 12 Case 5, 50Pa.g, 200mm aperture, 90°, D4, half LFL	46
Image 13 Case 5, 50Pa.g, 200mm aperture, 30°, D4, LFL	47
Image 14 Case 5, 50Pa.g, 200mm aperture, 30°, D4, half LFL	47
Image 15 Case 5, 4kPa.g, 100mm aperture, 30°, D4, LFL	48
Image 16 Case 5, 4kPa.g, 100mm aperture, 30°, D4, half LFL	48
Image 17 Case 6, 100Pa.g, 5000mm aperture, 15°, D4, LFL	49
Image 18 Case 6, 100Pa.g, 5000mm aperture, 15°, D4, hLFL	49

Appendices

A: Graphs of release events: plume outlines	41
B: Daesim Risk Assessor software	50

Executive summary

This study has considered a generic bio-gas system, typical of the meat processing industry. The study looked at understanding the hazards and associated risks of the facility.

Standard hazard identification processes were used to elicit and document the hazards and their potential for harm to people, plant facilities and the environment. Due recognition was taken of detection methods and safeguards that are typically installed.

The key hazards related to gas releases, possible fires and explosions. These events were considered by applying consequence analysis, where predictive models were used to estimate the impact of such events. Analysis of hydrogen sulphide releases was done indicating that on-site and off-site impacts could occur under a range of release scenarios.

These scenarios require application of inherently safer design principles and where necessary implementation of independent protection layers, including emergency response procedures to be in place in order to eliminate or mitigate loss of containment impacts.

In this study, the consequence estimates show that there is little potential for major off-site impacts from fires and explosions. Hence the risks beyond the boundary from these events are low. This is particularly the case given the general siting of these operations away from close proximity to residential areas.

Impacts from releases of gas from bio-gas transmission lines between the CALs and gas users or flare systems are considered low due to the low operating pressures. Impacts can be more significant on the downstream side of the blowers where pressures are higher.

However, there are potentially more serious impacts on-site in the case of large releases of gas from CALs, and the possibility of explosion impacts from enclosed space ignition of bio-gas in generator set installations.

Both situations have various levels of control and mitigation in place, particularly in relation to enclosed generator sets. However, multiple failures can occur in gas detection and ventilation systems that permit explosive atmospheres to form within these facilities. Physical location of the facility on the site is important to mitigate possible impacts from explosions. Where appropriate, the use of open, covered areas is an inherently safer design option.

The loss of containment of bio-gas containing large amounts of hydrogen sulphide beyond 0.2% (2000 parts per million by volume (ppmv)) can be significant, especially at night where effect distances can be greater than 500 metres from the release point.

Every effort should be made to ensure designs and operation minimise loss of containment events, and that on-site and off-site emergency response procedures are in place and are exercised on a regular basis.

A semi-quantitative consideration has been given to frequency of events that lead to potential impacts in order to perform the risk ranking of identified hazards. Full quantification is justified when the impacts can be significant and the designs are well defined.

A qualitative assessment was made of hazard impacts which showed no high level risks. Human failures in operating the bio-gas system are a key determinant in risk control, centred around procedures and maintenance issues.

Application of inherently safer design practice can help bring risks to as low as reasonably practicable through complete elimination of hazards. That should be the aim of all designs and operational considerations around bio-gas production and use.

1 Introduction

1.1 Objectives of the Study

The objectives were to:

- review bio-gas system designs, typical of those within the meat processing industry
- perform hazard identification studies to determine principal hazards
- carry out an assessment of the hazards and their potential impacts on vulnerable resources
- assess major incidents for such physical effects as fire, explosion and toxic exposure
- assess the risk through qualitative approaches and as necessary the use of quantified assessments.

1.2 Description of background issues

The issues from a hazard and risk perspective are:

1. What hazards are present?
2. What potential causes and consequences are associated with those hazards?
3. How big are the impacts?
4. What effects might flow from these hazards? Are they gas releases, flash fires, jet fires or deflagrations or explosions?
5. What is the likely risk in qualitative terms on a range of risk receptors such as people (PE), the plant itself (PL) or the environment (EN)?
6. What potential design guidelines and system controls are needed to maintain risk to as low as reasonably possible?

2 Description of bio-gas facilities

2.1 Typical bio-gas generation facilities

Operations include:

1. Production of meat processing effluent as feed to treatment facilities.
2. Generation of bio-gas in covered anaerobic lagoons (CALs).
3. Bio-gas transport systems from CALs to utility generation systems. This includes generator sets as well as feed to boilers.
4. Bio-gas utilization in engine-generator sets.
5. Bio-gas flaring systems.

Bio-gas facilities installed in the red meat processing industry are essentially designed as high density polyethylene (HDPE) lined earth dams with HDPE covers.

Figure 1 gives a process flow diagram / piping and instrumentation diagram (PFD/P&ID) that captures the principal characteristics of bio-gas systems related to CALs.

There are quite a number of variations in designs and the features deployed in these facilities. Some flare gas, others utilize gas for steam production or for generating electricity.

2.2 Safety systems

This following section reviews the key safety systems typically deployed for bio-gas generation and use.

1. Pressure relief on CAL covers via systems such as hydraulic dip legs cover spears, or weighted flap valves. These all vent to atmosphere.
2. Moisture knock-out pots to ensure no significant carry-over of liquids into the biogas transport system.
3. In-line methane analysers to continuously read bio-gas methane content.
4. Use of flare systems to burn unwanted bio-gas and also for over-pressure relief of the transport systems.
5. Ventilation of enclosed spaces occupying engine-generator sets.
6. Deployment of methane gas sensors as part of the safety instrumented system for power generation.
7. Bio-gas flaring systems: burner management with safety interlocks.

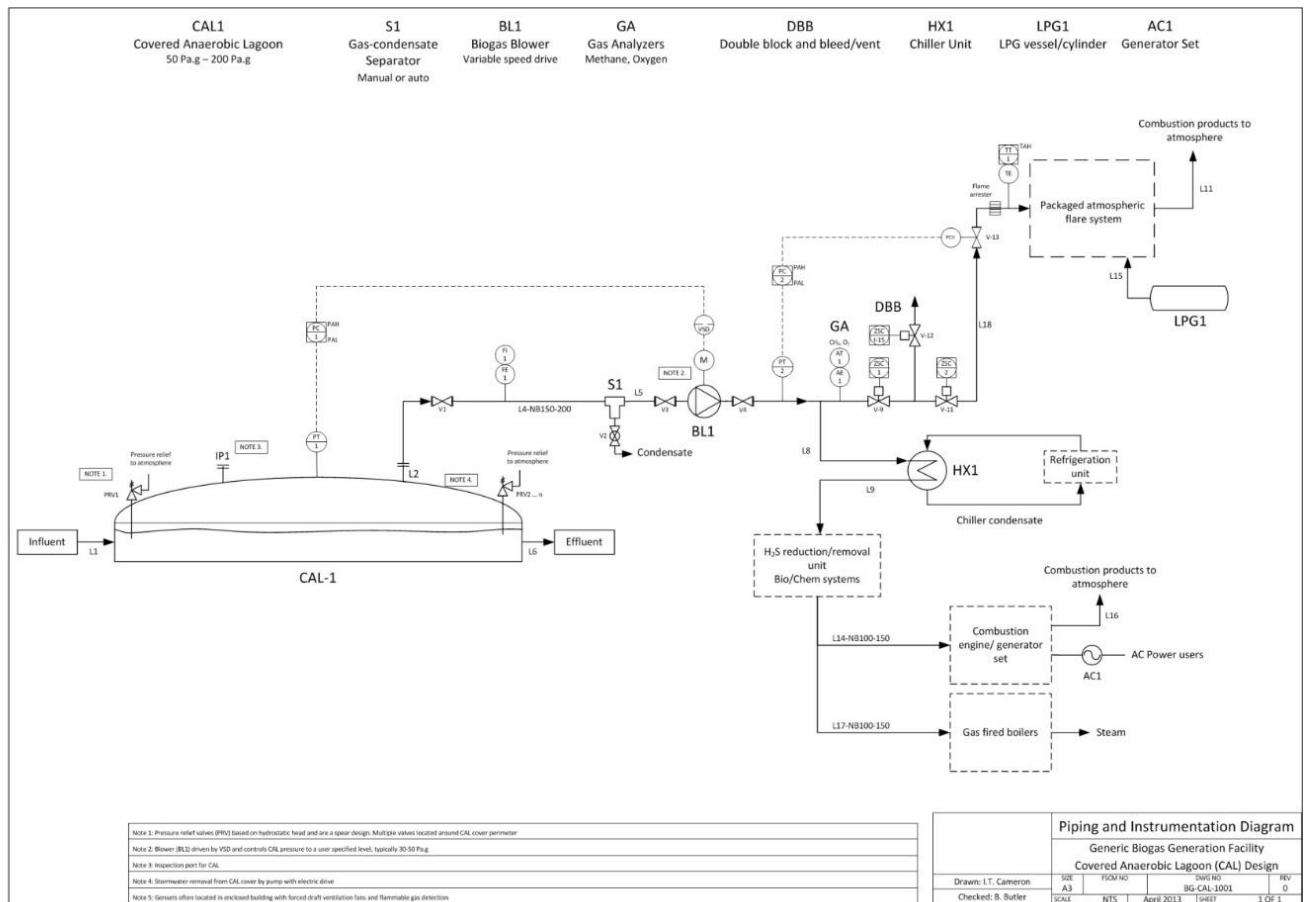

Figure 1. Generalised bio-gas system Piping and Instrumentation Diagram (P&ID)

3 Hazard identification and qualitative risk estimation

3.1 Hazards

The principal events having potential impact both on-site and off-site are primarily related to the hazardous properties of the biogas and the release locations. Bio-gas is flammable and consists primarily of methane and carbon dioxide with traces of other compounds such as hydrogen sulphide. It is therefore flammable and potentially explosive. These types of events within the biogas system need control, using both installed safety systems as well as physical separation of plant from vulnerable resources.

A bio-gas system is often composed of:

1. Influent feed system
2. Covered anaerobic lagoons (CALs)
3. Bio-gas transfer systems (BGT)
4. Flare systems
5. Bio-gas utility systems (UTIL).

A hazard identification (HAZID) exercise was carried out using a combination of loss of containment (LoC), Failure Modes and Effects Analysis (FMEA) and Hazard and Operability (HAZOP) study techniques. The outcomes are shown in Tables 2 to 5.

3.2 Past incidents and accidents

The history of bio-gas system operations and failures is relatively short in time. However, there have been a number of incidents recorded in relation to CAL operations in Australian and the US. These include:

1. Incident in Victoria at Rivalea that led to a large gas release and a flash fire which caused minor injury but no fatality.
2. Cover fires (under maintenance situations; storm-water removal systems with pumped removal of water with pump installed on the cover and lightning events).

No bio-gas system failures have been recorded to date in Australian CAL systems installed in the red meat processing industry. Johns Environmental estimates that the industry has approximately 120 CAL-years of operation across all the installations.

Hence the major event at Rivalea represents an event frequency of approximately 0.01 major gas releases per year per CAL.

3.3 Risk ranking and qualitative estimation

As well as the hazard identification task, risk ranking via qualitative estimates was made of the potential impacts and frequency on risk receptors such as people (PE), environment (EN) and plant (PL).

These qualitative estimates were performed using a 5 x 5 risk matrix with axes graded 1 to 5 for

severity and A to E for frequency per year. The subsequent qualitative risk levels within the matrix were graded as: Very high (VH), High (H), Medium (M) and Low (L).

It should be noted that risk aversion for multiple fatalities has been indicated by classing any occurrence as High or Very High.

The purpose of such estimates is to rank initial risk estimates to focus on the most important risk eliminations or reductions. This ranking can be assigned to 3 primary regions of the risk matrix (Table 1):

1. Risks that always require elimination or reduction through inherently safer designs (ISD) or via risk reduction actions, such as layer of protection analysis (LOPA).

This is represented in Table 1 by areas of High (H) and Very high (VH) risks.

2. Risks that are considered to be in the “As Low As Reasonably Practicable” (ALARP) region, where risk reduction should be practised based on cost-benefit analysis.

This is represented by the Medium (M) risk regions.

3. Risks that are low and should be managed for continuous improvement.

This is represented by the Low (L) risk regions.

The following characteristics should be noted:

The qualitative risk matrix, combines potential severity of the event with the possible frequency of the event to get qualitative risk estimates as Severity x Frequency (S x F) as shown in Table 1. The details of severity levels and frequency ranges represented in the risk matrix for different risk receptors are now discussed.

Table 1. Qualitative risk matrix

CONSEQUENCE				FREQUENCY (yr ⁻¹)				
Increasing severity	People (PE)	Environment (EN)	Assets (AS)	A	B	C	D	E
				<0.001 or <1 in 1000 years	0.001-0.01 or between 1 in 100 to 1 in 1000 years	0.01-0.1 or between 1 in 10 to 1 in 100 years	0.1-1 or between 1 in 1 to 1 in 10 years	>1 or >1 a year
1	Slight injury	Low pollution	Negligible damage	L	L	L	M	M
2	Minor injury	Minor pollution	Minor damage	L	L	M	M	H
3	Major injury	Moderate pollution	Moderate damage	L	M	M	H	VH
4	Fatality	Major pollution	Major damage	M	M	H	VH	VH
5	Multiple fatalities	Extreme event	Extreme damage	H	H	VH	VH	VH

1. Typical severity scales are:

(i) People (PE):

1 = Slight injury (no medical treatment needed)

2 = Minor injury (medically treated injury)

3 = Major injury (potentially permanent effects, hospitalization)

4 = Fatality

5 = Multiple fatalities

(ii) Environment (EN):

1 = Low pollution (no observable effects)

2 = Minor pollution (minor effects on plant and animals; contained impacts, cleanup)

3 = Moderate pollution (moderate effects on plants and animals, extensive cleanup, report to authorities)

4 = Major release (major effects on plants and animals, possible prosecution, substantial cleanup)

5 = Extreme event (permanent environmental effects, possible loss of licence to operate, possible company and director prosecutions)

(iii) Assets (AS):

1 = Negligible impact (no equipment damage, no loss of production)

2 = Minor (minor/superficial damage to equipment/facility, minor impact on production)

3 = Moderate (moderate damage and significant loss of production)

4 = Major (requires significant preventative/corrective actions, serious loss of production)

5 = Extreme impacts (future operation seriously affected, urgent corrective action, major loss of production)

2. Typical frequency ranges would be:

A = less than 1 in 1000 years (frequency, $f < 0.001$ per annum.)

B = between 1 in 100 to 1000 years (f range is 0.001 – 0.01 p.a.)

C = between 1 in 10 to 100 years (f range is 0.01 – 0.1 p.a.)

D = between 1 in 1 to 10 years (f range is 0.1 – 1 p.a.)

E = greater than 1 per annum. ($f > 1$ p.a.)

The above severity and frequency scales were used to estimate qualitative risks that are presented in Tables 2 to 5 for each of the sub-systems of a typical bio-gas facility.

3.3.1 Residual risks

Importantly, the risk estimates are to be interpreted as “residual” risks, which incorporate the risk reduction contributions of typical mitigation and safety systems that are commonly being implemented in the bio-gas industry.

The risks related to people on-site considered a probability of exposure PE to the hazardous event, as well as a probability of gas ignition P11 when flammable gas releases were involved. Again this was classed as:

High (H) = almost certainly in the event area (PE > 0.9),

Medium (M) = occasionally in the area (PE ~ 0.5), or

Low (L) = rarely in the area (PE < 0.1)

In the case of environmental and asset impacts, the exposure probability of the risk receptor was assumed to be 1. The residual risk estimates (R) are shown in Tables 2 to 5.

In making the risk rankings for identified events, a semi-quantitative approach was taken that used some generic failure rates for certain equipment types. These frequencies² included:

1. Major and total failure of DN 200-350 steel pipelines: 6×10^{-7} /yr/m
2. Major failure of valves: 1×10^{-3} /yr
3. Flange or connection failures: 1×10^{-2} /yr
4. Reciprocating compressor failure: major 1×10^{-4} /yr; minor 1×10^{-2} /yr.
5. Ventilation electric motor failure: 1×10^{-1} /yr

Little information is available on failure rates and reliability of equipment operating in the bio-gas industry and as such the generic oil and gas data were used. For pipelines a segment length of 10m was used as a basis for frequency estimates.

Off-site individual risks would normally assume constant exposure to any risks generated from bio-gas operations. However, given the general location of bio-gas facilities and the use of separation distances between bio-gas facilities and sensitive land uses, the risks to the general public are likely to be low.

For specific plant locations and surrounding sensitive land uses, quantified risk assessment would be required to assess the imposed risks and adequacy of the proposed design and operations.

¹ Immediate gas ignition probabilities for releases in the chemical/gas industry are around 0.04. See VROM (2005).

² See several references including: VROM (2005), UK-HSE (2012), CCPS (1989).

Table 2. Influent feed system

ITEM	HAZARD OR EVENT	POSSIBLE CAUSES	POSSIBLE CONSEQUENCES	DETECTION/PROTECTION MEASURES	RESIDUAL RISKS (S X F = R)		
					PE*	EN	AS
INF1	Loss of containment of raw influent	<ul style="list-style-type: none"> Cover anchor trench failure Blockage in feed line/trench Inspection/cleaning failures Blockage in CAL outlet 	<ul style="list-style-type: none"> Spill to environment Contamination of land and/or water courses Business interruption Legal action by authorities or affected parties Erosion of CAL walls 	<ul style="list-style-type: none"> Best practice for the industry Regular inspections of feed systems Preventative maintenance measures Upstream pre-treatment to minimize downstream blockages Access points for cleaning purposes Gravity flow to CALs reduces system pressure 	1 x A = L (PE = L)	3 x C = M	2 x C = L
INF2	Excess bio-gas production	<ul style="list-style-type: none"> CAL under-design Strong organic stream spills upstream of CAL 	<ul style="list-style-type: none"> Bio-gas production exceeds flare capacity Overpressure of CAL and controlled gas release Overpressure of CAL, failure of pressure relief and uncontrolled gas release with jet fire or flash fire Odour release through overpressure release devices 	<ul style="list-style-type: none"> Appropriate feed stream characterization Appropriate design factors used in CAL design & flare sizing Upstream pre-treatment to minimize shock loads 	1 x C = L (PE = L, Pi = L)	1 x D = M	2 x C = M

****People:** Considers the probability of a person present in the area (PE). For gas releases, a probability of ignition (Pi) is also included. This was typically < 0.1

Table 3. Covered anaerobic lagoons (CALs)

ITEM	HAZARD OR EVENT	POSSIBLE CAUSES	POSSIBLE CONSEQUENCES	DETECTION/PROTECTION MEASURES	RESIDUAL RISKS (S X F = R)		
					PE*	EN	AS
CAL1	Release of liquid contents from CAL	<ul style="list-style-type: none"> Breach of lagoon containment wall and lining Breach of lining and seepage to ground Failure of tank wall (concrete systems) Human failure on sludge recirculation system 	<ul style="list-style-type: none"> Release of effluent to environmentally sensitive areas Major business interruption Legal action by authorities or affected parties Odour release 	<ul style="list-style-type: none"> Construction best practice standards for CALs Inspection and leakage detection especially trench below liner pipe. Isolation of spill Spill control and recovery procedures Emergency response procedures Separation distances to vulnerable resources Low probability of people in area, site layout planning Strict control of ignition sources 	$1 \times C = L$ $(P_E = L)$	$3 \times C = M$	$3 \times C = M$
CAL2	Large release of bio-gas from CAL	<ul style="list-style-type: none"> Overpressure of CAL Major failure of cover material Large weld failure Catastrophic failure of CAL fittings Significant mechanical impact Retaining cables cutting cover De-anchoring of cover 	<ul style="list-style-type: none"> Dispersion of gas to atmosphere Gas release, immediate ignition and jet fire Gas release, delayed ignition and flashfire Dispersion of hydrogen sulphide and possible human impacts 	<ul style="list-style-type: none"> Material standards Inspection regimes esp. on seam welding Pressure relief devices around CAL perimeter. Separation distances to vulnerable resources Low probability of people in area Lightning protection Strict control of ignition sources 	$4 \times A = M$ $(P_E = L, P_I = L)$	$1 \times A = L$	$4 \times A = M$
CAL3	Small release of bio-gas from CAL	<ul style="list-style-type: none"> Overpressure of CAL Failure of cover material Weld failure Failure of CAL fittings Mechanical impact Retaining cables cutting cover 	<ul style="list-style-type: none"> Dispersion of gas to atmosphere Gas release and immediate ignition Gas release and delayed ignition Air ingress to CAL and potential partially 	<ul style="list-style-type: none"> Construction standards Inspection regimes Dip-leg pressure relief devices Separation distances to vulnerable resources Low probability of people in area Open ports only when cover is flat on water, 	$2 \times B = L$ $(P_E = L, P_I = L)$	$1 \times D = M$	$2 \times D = M$



ITEM	HAZARD OR EVENT	POSSIBLE CAUSES	POSSIBLE CONSEQUENCES	DETECTION/PROTECTION MEASURES	RESIDUAL RISKS ($S \times F = R$)		
					PE*	EN	AS
		<ul style="list-style-type: none"> Partial seam failure of cover with lagoon lining Open ports in cover when inflated 	<ul style="list-style-type: none"> confined explosion Legal action by authorities or affected parties 				

****People:** Considers the probability of a person present in the area (P_E). For gas releases, a probability of ignition (P_I) is also included. This was typically < 0.1

Table 4. Bio-gas transfer systems

ITEM	HAZARD OR EVENT	POSSIBLE CAUSES	POSSIBLE CONSEQUENCES	DETECTION/PROTECTION MEASURES	RESIDUAL RISKS (S X F)		
					PE**	EN	AS
BGT1	Small release of bio-gas from system	<ul style="list-style-type: none"> Line minor failure Poor fabrication practices and weld/joint leaks Valve/gasket/flange minor failure Blower leak Lightning strike Human failure in leaving KO pot condensate valve open. External impact 	<ul style="list-style-type: none"> Ignition and localized jet fire Radiation impact on nearby equipment Dispersion to atmosphere with no ignition Dispersion of hydrogen sulphide and possible human impacts 	<ul style="list-style-type: none"> Construction standards Inspection regimes Isolation of system Flaring of gas, depending on leak location Separation distances to vulnerable resources Low probability of people in area System earthing Strict control of ignition sources Vehicle protection barriers 	2 x A = L	2 x B = L	2 x B = L
BGT2	Large bio-gas release from system	<ul style="list-style-type: none"> Major line failure (rupture) Welding/maintenance failure Lightning strike Blower failure Operational failure External impact 	<ul style="list-style-type: none"> Ignition and localized jet fire Radiation impact on nearby equipment Dispersion to atmosphere with no ignition Dispersion and delayed ignition leading to flash fire or deflagration Dispersion of hydrogen sulphide and possible human impacts Legal action by authorities or affected parties 	<ul style="list-style-type: none"> Construction standards Inspection regimes Isolation of system Flaring of gas, depending on leak location Separation distances to vulnerable resources Low probability of people in area Strict control of ignition sources Vehicle protection barriers 	2 x A = L ($P_E = L, P_I = L$)	2 x B = L	3 x B = M

****People:** Considers the probability of a person present in the area (P_E). For gas releases, a probability of ignition (P_I) is also included. This was typically < 0.1

Table 5. Bio-gas utility generation system

ITEM	HAZARD OR EVENT	POSSIBLE CAUSES	POSSIBLE CONSEQUENCES	DETECTION/PROTECTION MEASURES	RESIDUAL RISKS (S X F = R)		
					PE*	EN	AS
UTIL1	Small release of gas in utility generation area	<ul style="list-style-type: none"> Line failure Valve/gasket/flange failure Drain valve fails open Pressure relief valve leaks Engine leaks Poor maintenance Operating failure from human error 	<ul style="list-style-type: none"> Localised jet fires on immediate ignition Dispersion into room and no ignition Dispersion and delayed ignition with deflagration Structural damage and business interruption Dispersion of hydrogen sulphide and possible human impacts 	<ul style="list-style-type: none"> Construction and equipment design standards Gas Act Hazard zone classifications and equipment Ventilation systems Restrictions on entry Training systems Location on site Strict control of ignition sources 	3 x A = L (PE = L, PI = L)	2 x A = L	3 x B = M
UTIL2	Large gas leak in utility generation area	<ul style="list-style-type: none"> Major failure of lines Significant failure of gas-line components (valves, instruments) Failure of engine components Poor maintenance Operational failure 	<ul style="list-style-type: none"> Localised jet fires on immediate ignition Dispersion into room and no ignition Dispersion and delayed ignition with explosion Major structural damage, business interruption Potential for death if people exposed to event via missile impacts or flashfire Dispersion of hydrogen sulphide and possible human impacts Legal action by authorities or affected parties 	<ul style="list-style-type: none"> Construction standards Ventilation systems Gas detection Restrictions on entry Training systems Location on site Strict control of ignition sources Interlock systems on equipment failures with isolation and flaring 	4 x A = M (PE = L, PI = L)	2 x A = L	4 x A = M

****People:** Considers the probability of a person present in the area (PE). For gas releases, a probability of ignition (PI) is also included. This was typically < 0.1

3.4 Major accident events to be considered

From the events listed in Tables 1 to 4 the following major incidents were identified:

1. Flash fires due to unconfined release of bio-gas and subsequent delayed ignition of the flammable cloud
2. Deflagrations of partially confined bio-gas clouds with ignition
3. Explosions of a flammable bio-gas cloud in a confined space such as the generator set building
4. Low velocity jet fires from releases and ignition of bio-gas from failure in transfers systems.
5. Releases of bio-gas containing hydrogen sulphide.

The general location of these events is shown in Figure 2, identified by their location as either:

1. Covered anaerobic lagoon area (CAL)
2. Biogas transmission system (BGT)
3. Utility generation system (UTIL).

Section 4 of this report analyzes the possible physical effects of events occurring in these areas to provide information on impact zones affecting people, the environment and the biogas and associated plant.

4 Consequence analysis of events

This section analyses the key events and their potential impacts in terms of hazard distances for various scenarios. In the case of fire, key thermal radiation levels of 4.7 kW/m² and 23kW/m² are normally considered for nearby residential areas and adjacent industrial sites. These are key thermal radiation levels of concern.

In the case of deflagration or explosion overpressures the key levels of concern are 7kPa and 14kPa. The first relates to impacts on residential areas, whereas the higher level of 14kPa relates to nearby industrial activities.

The following consequence analyses consider fires associated with cover failures and other loss of containment events from equipment items. It also covers potential open flammable cloud (OFC) flash fires and/or explosions from bio-gas releases, as well as confined flammable gas deflagrations and explosions, such as those inside buildings.

The key events analysed include:

1. Releases of bio-gas from the CAL cover, subsequent fires (jet fire (JF), flash fire (FF))
2. Releases of bio-gas from transmission systems (JF, FF)
3. Releases of bio-gas at generator facility (vapour cloud explosion (VCE), JF)
4. Release of bio-gas and downwind impacts of hydrogen sulphide.

Figure 2 shows the overall system and location of the key events, as seen in the shaded octagon locations.

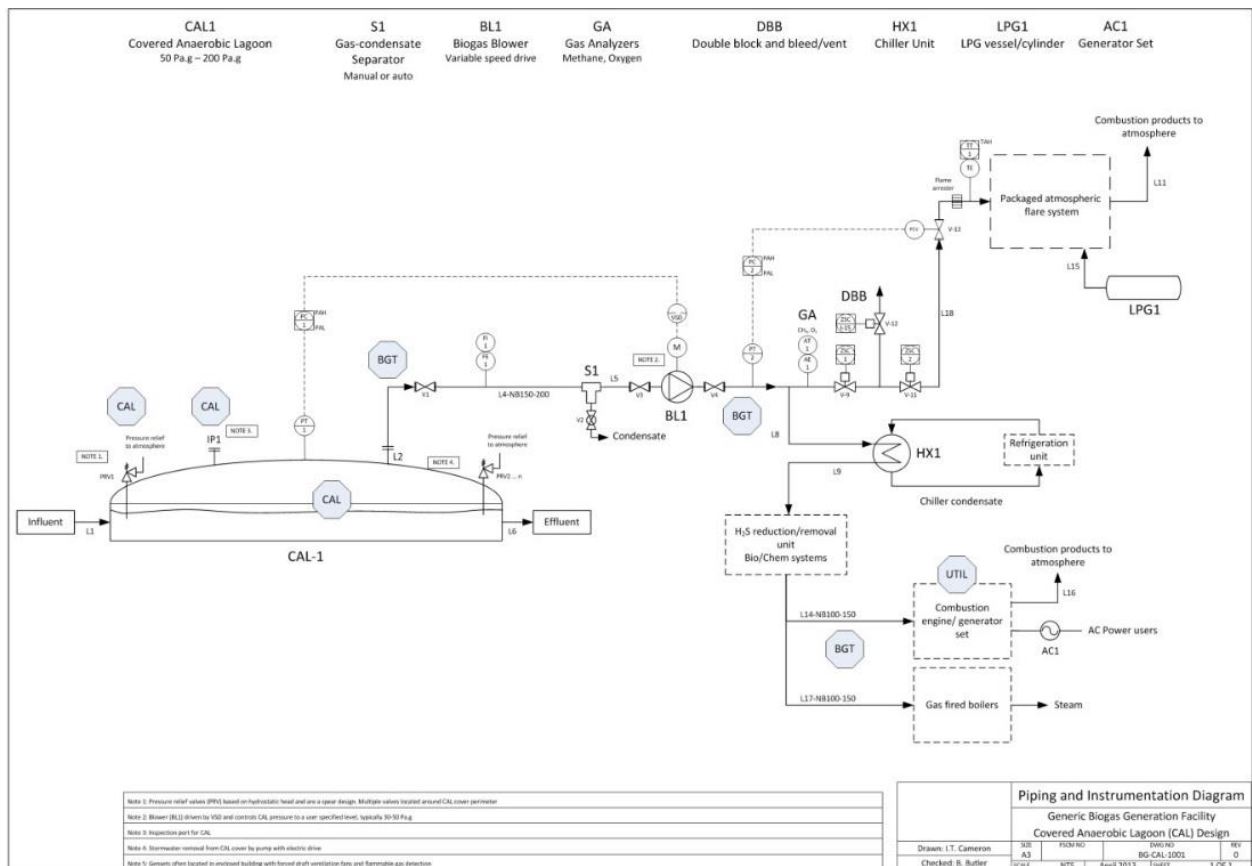

Figure 2 Location of key events for biogas hazards and risks (CAL, BGT and UTIL)

4.1 Analysis of consequences from key events

4.1.1 Fire radiation from flammable releases: underlying assumptions

The principal consequences arising from flammable bio-gas is thermal radiation from various forms of fire, be they jet fires or open flammable cloud fires (OFC). The basic assumptions used in estimating these thermal radiation levels include:

- Ambient temperature of 25°C
- Ambient relative humidity of 60%
- Methane as the flammable substance (70 vol %) with balance being carbon dioxide
- Atmospheric conditions were given as Pasquill-Gifford wind speed combinations of D4 and F2, these being representative of day and night atmospheric conditions (stability class and wind speed)
- Release pressures for the CAL consisted of 50 Pa.g and 100 Pa.g, with a particular case of 200 Pa.g
- Releases for the bio-gas transmission system varied between 50 Pa.g for the gathering systems to 4 kPa.g for feed to the generator set.

- Release sizes were as follows:
 - CAL cover: major failure of cover equivalent to 1m diameter opening
 - CAL cover: discharges from inspection ports or pressure relief devices (50mm to 200mm diameter)
 - Piping systems: full bore failure of 50mm diameter
 - Piping systems: full bore failure of 200mm diameter
 - Genset area: full bore failure of 100mm diameter line.

4.2 Event consequence modelling

The following models were used in estimating the effects from accidental releases.

For bio-gas release, the Aeroplume model within the HG System (Shell 2006) was used, and for subsequent ignition a jet fire model based on Chamberlain was used (TNO 1997a), or in some cases for very low velocity flows a modified point source model was used to estimate thermal radiation impacts (Cameron & Raman 2005).

In the case of the biogas releases, the dispersion of the low pressure gas jet was estimated to both the lower flammability limit (LFL) and to half the lower flammability limit ($\frac{1}{2}$ LFL).

4.3 Impact analysis for Covered Anaerobic Lagoon events

The analysis was done for the following conditions:

1. Release pressure of 50 Pa.g, 100 Pa.g and one case at 200 Pa.g.
2. Gas release at 30° down to 0° from the horizontal.
3. Height of release was 1.5m above grade.
4. Gas temperature was assumed to be 50°C.
5. Ambient temperature was assumed to be 25°C.
6. Land surface roughness was set at $z_0 = 0.03\text{m}$ (open, flat terrain).
7. Stability, wind speed class was D4 (neutral atmospheric stability and 4m/s).
8. A stability, wind speed class of B2 (highly stable atmosphere and 2 m/s wind speed) was also run to check if significant differences in LFL and $\frac{1}{2}$ LFL were predicted.
9. The composition of bio-gas was assumed as 70 volume % methane and 30 volume % carbon dioxide. (It is recognized that some hydrogen sulphide is also in the bio-gas between 200 – 2000 ppm, although some very rare cases at 80,000 ppm have been recorded).
10. Bio-gas LFL was 7.2 vol. % and $\frac{1}{2}$ LFL was 3.6 vol. %. The UFL was 21.4 vol. %.

The estimates considered a large failure of the CAL cover of equivalent diameter of 1 metre. It also considered some releases from pressure relief devices and inspection ports.

Table 5 gives the effect distances to the LFL and $\frac{1}{2}$ LFL concentrations of biogas. It shows the assumed discharge angle, system pressure, hole diameter, gas release rate and then effect distances.

Table 6 CAL cover releases: effect distances

Case #	Release angle from horizontal (°)	Release pressure (Pa.g)	Equivalent hole diameter (mm)	Gas release rate (kg/s)	Distance to LFL (m) and jet tip elevation (m)	Distance to ½LFL (m) and jet tip elevation (m)	Comments
1	30	50	1000	7.6	12 @ 5.6	20 @ 7.4	Low pressure release at an angle of 30° produces a rising release with little gas at ground level
2	30	100	1000	10.7	15 @ 6.9	23 @ 9	Similar to case 1
3	15	200	1000	15.2	22 @ 6	36 @ 8	Low angle releases cause some gas to touch ground and lower plume height
4	0	200	1000	15.2	55 @ 2.6	67 @ 4.0	At 0° release, there is significant ground interaction which promotes longer and lower plumes
5	90	50	200	0.31	1.2 @ 1.7	2.5 @ 3.7	Very short low pressure plumes highly localized
6	15	100	5000	268	61 @ 25	95 @ 34	A very large tear in the CAL cover

The outlines of the gas plumes from the various CAL releases are shown in Appendix A.

It should be noted that the amount of bio-gas contained in the dispersive plumes for all the cases in Table 6 is less than 100 kg. As such these releases upon delayed ignition would lead to flash fires, and potentially a low velocity jet fire on flashback. Most releases have discharge velocities less than 20 m/s.

The significance of these predictions is:

1. Low pressure, small diameter releases from cover attachments like inspection ports (case #5) which are essentially vertical will rise rapidly and disperse. If ignited they would lead to a flame of low emissive power (kW/m²).
2. Large scale releases from cover failures of substantial aperture such as 1m diameter disperse rapidly in the case of orientations above 20° above the horizontal and have little impact at ground level. See case #1, 2 and 3.
3. Large gas releases from the cover which are near horizontal in orientation and have subsequent ground interaction can have significant distances to the LFL and ½LFL, These present a flash fire risk. This can necessitate an ignition exclusion zone around CALs of up to 40-50m. In particular, see case #4.
4. Larger failures than 1 metre equivalent diameter at the base of the cover, with close to horizontal discharge could generate larger effect distances (>50m).
5. It is highly likely that given the very open ground location of CALs that ignition of an open flammable cloud would simply result in a flash fire. Anyone caught inside the cloud would have a very high probability of death.
6. Tests on comparing dispersion outcomes at B2 (night-time) atmospheric conditions with outcomes using D4 (day-time) conditions suggests no real differences in effect distances.

Implications:

1. Exclusion distances beyond the standard hazardous zone estimates should be established for potential ignition sources, to minimize the possibility for flash fire events in the case of major releases from CAL covers.
2. It is essential that any 'Hot' work carried out near CALs be strictly controlled and consideration given to the likelihood of ignition of bio-gas releases.
3. Reliability of pressure relief systems on the CAL is vital in order to minimize effects of blocked spears and the subsequent overpressure of the covers. The failure of highly inflated covers could generate plumes that can have ground contact and hence extended effect distances.

4.4 Impact analysis for biogas transmission events

4.4.1 Gas releases under varying conditions

Similar basic bio-gas conditions were assumed as discussed in section 4.2

Bio-gas transmission as seen in Figure 1 relies on the operation of a low differential pressure blower to move gas from the CAL to flare or to other operations such as generators sets and boilers.

The pressure profile in gas transmission lines runs from the typical CAL operating pressure of 50 Pa.g down to a slight negative pressure at the suction side of the blower. The blower typically boosts bio-gas pressure to 2 to 4 kPa.g for subsequent flaring or power generation applications. A range of hole sizes from 50mm to 200mm was investigated.

Table 6 sets out results for the cases studied within the bio-gas transmission system. These were done for D4 atmospheric conditions.

Table 7 Bio-gas releases from gas transmission: effect distances

Case #	Release angle from horizontal (°)	Release pressure (Pa.g)	Equivalent hole diameter (mm)	Gas release rate (kg/s)	Distance to LFL (m) and jet tip elevation (m)	Distance to ½LFL (m) and jet tip elevation (m)	Comments
1	30	50	200	0.31	3.2 @ 1.9	5.7 @ 2.6	Typical of the line leaving the CALs
2	30	4 kPa.g	100	0.67	3.8 @ 3.1	6.5 @ 3.8	On discharge side of blower
3	30	5 kPa.g	100	0.75	4.2 @ 3.3	6.8 @ 4	On discharge side of blower
4	30	5 kPa.g	200	3.0	7.5 @ 4.8	12.9 @ 6.3	On discharge side of blower

Tests on comparing dispersion outcomes at B2 atmospheric conditions with outcomes using D4 conditions suggest no significant differences in effect distances.

The significance of these predictions for bio-gas releases from transmission systems is:

1. Low pressure releases from piping systems (like case #1) can be vertical to near horizontal, and

in the case where there is no ignition the bio-gas will rise and disperse rapidly.

2. Larger releases from transmission systems are experienced under higher pressure, such as cases #2, 3 and 4. The profiles for LFL and half LFL (½LFL) are given in Appendix A. Again, the discharge orientation will determine potential impact zones, with vertical discharges easily dispersed.
3. There is a small probability of immediate ignition of bio-gas. The impacts of this are assessed in the next section.

4.4.2 Low pressure jet fires

If low pressure gas releases are immediately ignited then they will burn as a small jet fire. Several situations were investigated to determine the potential impacts from such events and the typical distances to thermal radiation levels of interest. In most cases, depressurisation of the transmission system would take place as the gas is released. However, on the discharge side of the blower, gas releases could be sustained for much longer periods until the blower is shut down and isolated.

When ignited these jet releases would lead to a flame with surface emissive power (SEP) of around 150- 200kW/m².

The important thermal radiation levels of concern are 4.7 kW/m² and 23 kW/m², which represent key impact levels for residential and industrial risk receptors. The level of 23 kW/m² is also important for impacts on onsite steel (and non-metallic) structures. On steel structures this level of impact can cause failure within 15-20 minutes. On timber structures this level of thermal impact can cause rapid ignition of these structures and subsequent escalation of the initial event.

Table 7 gives thermal radiation estimates for two key events. One is a low pressure release at 50 Pa.g through a 200mm opening, the other is a higher pressure release of 4 kPa.g through a 100mm opening, typical of piping size supplying energy generation systems. The distances are at 1m above grade and lateral to the axis of a vertical flame.

A view factor model was used, which assumed a SEP of 200kW/m² radiative fraction of methane was 0.2 of the energy released, and atmospheric transmissivity of 0.8.

Table 8 Thermal radiation estimates for bio-gas jet fires

Case #	Conditions Pressure + diameter (mm)	Gas release rate (kg/s)	Energy released (kW)	Estimated flame length (m)	Lateral distance to 23kW/m ² for a vertical flame (m)	Lateral distance to 4.7kW/m ² for a vertical flame (m)
1	50 Pa.g: 200mm	0.31	12100	2	3	6
2	4 kPa.g: 100mm	0.67	24800	6	4	9

Significance of the estimates:

1. Flame impacts will depend on the orientation of the release.
2. The most likely issue is flame impingement on nearby equipment.
3. For ignited release that are near horizontal, the important impact distances are only several metres beyond the end of the flame. The target simply “sees” the end of the flame shape, and not the full flame profile.
4. The estimates show that effect distances are small, with only localized effects such as possible impingement of the flame on nearby objects.
5. The potential for human impact is extremely low, since people can easily move from the area.
6. It is also likely that bio-gas flow measurements in the transmission system will indicate that an event has happened and emergency response should quickly isolate the source of the release.

Implications:

1. In laying out pipe runs and equipment, due recognition should be given to potential gas releases and ignition that could lead to damage by flame on nearby objects.
2. Consideration should be given in design to isolation strategies, particularly where long pipe runs are planned.
3. Consideration should be given to fire escalation if flames cause grass fires and these propagate. Open areas should have hazards minimized to reduce escalation.

4.5 Impact analysis for biogas utility generation

Bio-gas is often used on-site for the generation of steam via gas fired boilers or sometimes used for generation of power through the use of generator sets. For many installations the generator sets are located in enclosed buildings and not in open air situations.

The enclosed buildings are usually equipped with ventilation systems and in some cases gas detection.

With the possibility of significant gas releases into the building and the presence of ignition sources, there is the chance of gas explosions when gas concentrations are between the lower and upper flammability limits. This relates to 7.1 to 21.4 volume % of biogas or 5 to 15 volume % of methane. This requires analysis of explosion overpressures in the event of gas release and delayed ignition. For the case where ignition of (??) the gas release is immediate, a jet fire will occur.

For a generator set building with a volume of 700m³ (12m x 12m x 5m), a 100mm NB gas line operating at 4kPa.g will discharge ~0.7kg/s of biogas into the building. At the upper flammability limit (UFL) of 21.4 vol. %, this represents approximately 70kg of methane in the building. At a

constant release rate of 0.7kg/s this takes 100 seconds, although pressure drop in the line and blower capacity under these circumstances might reduce the release rate over time.

Due to the confinement in the building there is an increased risk of explosion compared with deflagration for open air situations. The explosion will have significantly higher overpressures compared with a deflagration or simply a flash fire. The next section investigates the explosion impacts.

4.5.1 Explosion events

To estimate impact distances to 7 kPa and 14 kPa overpressure a Multi-energy model (MEM) was used as well as a simple TNT model (TNO 1997). The MEM used a blast strength of 7, which represents a significantly confined vapour cloud situation. Figure 3 shows the overpressure profile from the blast centre, assuming that the building cladding provides no significant attenuation of the blast.

The estimates show:

1. 14 kPa overpressure at ~75m
2. 7 kPa overpressure at ~120m.

The value of 7kPa relates to maximum overpressures at residential locations, whilst 14kPa overpressure relates to nearby industrial activities. The implications are important for locating the enclosed genset facility on the bio-gas site in order to minimize overpressure effects in the case of an accident.

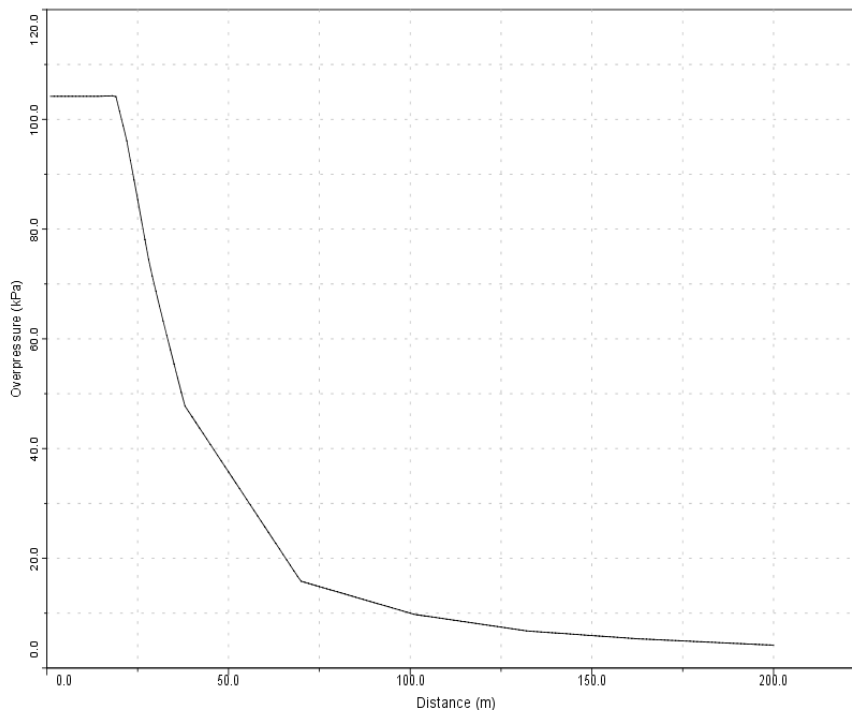

Figure 3 Overpressure from Genset building gas explosion

Significance:

1. The explosion overpressures from confined bio-gas explosions can have significant on-site implications, and potential off-site impacts depending on location of the genset facility in relation to other land uses.
2. The confinement of flammable vapour greatly increases blast overpressures.
3. It only takes a short time to reach the bio-gas UFL level in the event of ventilation failure and gas release by which time there is sufficient gas to generate an explosion if it is ignited.
4. Siting of facilities is important, both for on-site impacts and for off-site impacts.
5. Human injury or death is most likely due to shrapnel and flying objects rather than the blast overpressure.
6. At an overpressure of 7kPa, significant window breakage will occur.

Implications:

1. If possible, where noise control and other factors permit, at least 2 sides of any genset enclosure should be open to allow dispersion of any gas releases. This will minimize any explosive effects and would generate a low pressure flash fire rather than an explosion.
2. Clearly, strict controls on ignition sources within any enclosure is essential, as is the reliability of ventilation systems.
3. Ventilation systems must be designed such that they effectively disperse any gas releases. It is likely that any ventilation system will not be able to handle a large, instantaneous release of gas. Using simple enclosed volume turn-overs can deal with fugitive emissions but would not be truly effective on acute events such as a line rupture.

4.6 Impact of hydrogen sulphide within bio-gas releases

Analysis of hydrogen sulphide (H₂S) impacts that occur with bio-gas releases were analyzed for several scenarios:

1. Bio-gas loss of containment from the CAL
 - (i) 1000mm diameter release with CAL pressure of 100 Pa.g
 - (ii) 200mm diameter release at 50 Pa.g.
2. Bio-gas loss from transmission systems, after blower
 - (i) 100mm diameter release at 4 kPa.g
 - (ii) 200mm diameter release at 5 kPa.g.

The basic assumptions used in predicting downwind concentrations of H₂S were:

1. Release concentrations of 2000 ppmv (0.2% by volume, 0.278 wt %) and 50,000 ppmv (5% by volume, 6.627 wt %) of H₂S.
2. Horizontal release at a height of 1m above grade.
3. Ambient temperature of 20°C.
4. Rural dispersion conditions, where few obstacles are present.
5. Two atmospheric conditions of unstable atmosphere and moderate winds of 4 m/s (B4), and very stable night time conditions and low wind speed of 2 m/s (F2).
6. Use of a simple, standard Gaussian dispersion model (CCPS, 2000) assuming very low momentum releases.

These assumptions are regarded as conservative. Any detailed studies for particular site configurations should be done with specific assumptions relevant to the situation.

The simulations were done to estimate ground level concentrations down the centerline of the plume (highest downwind concentrations).

Table 9 H₂S impacts from CAL releases

Scenario	Total gas release rate (kg/s)	H ₂ S release rate (kg/s)		Distances from release (m)	Gas concentrations (ppmv) at various downwind distances for 2 key atmospheric conditions			
		0.2 vol %	5 vol %		0.2 vol % H ₂ S		5 vol % H ₂ S	
					B4	F2	B4	F2
1000mm diameter release @ 100 Pa.g	10.7	0.0297	0.7091	50	34	950	821	22694
				100	9	439	208	10492
				500	0.4	24	8	582
				1000	0.09	7.1	2.2	169
200mm diameter release @ 50 Pa.g	0.31	0.00086	0.0205	50	1	27	24	656
				100	0.25	13	6	303

	500	0.01	0.7	0.25	17
	1000	0.003	0.2	0.05	4.9

It can be seen that under a range of conditions, high concentrations of H₂S can exist for distances beyond 500m. These events are analyzed more closely in the risk assessment in section 5.4

Table 10 H₂S impacts from bio-gas transmission releases

Scenario	Total gas release rate (kg/s)	H ₂ S release rate (kg/s)		Distances from release (m)	Gas concentrations (ppmv) at various downwind distances for 2 key atmospheric conditions			
		0.2 vol %	5 vol %		0.2 vol % H ₂ S		5 vol % H ₂ S	
					B4	F2	B4	F2
100mm diameter release @ 4 kPa.g	0.67	0.00186	0.0444	50	2.2	60	52	1421
				100	0.55	27	13	657
				500	0.02	1.5	0.5	36
				1000	0.006	0.44	0.13	10.6
200mm diameter release @ 5 kPa.g	3	0.00834	0.199	50	9.7	267	230	6362
				100	2.5	123	58	2942
				500	0.1	6.8	2.4	163
				1000	0.025	2	0.6	47

5 Qualitative Risk Analysis and Assessment

5.1 Overview

In this section, a qualitative assessment is made on the individual and overall risks of bio-gas facilities. This considers the identified hazards, which mostly arise from release of bio-gas from containment, either at the CALs, or within the gas transmission system or end-use facilities. The study does not deal with the commercial flare systems that are provided by third parties, nor the issue of odour from sulphurous releases.

What is clear from the hazard identification and consequence analysis is that effect distances for the events considered in the study are limited to the processing site, given the location of these operations. Many events from gas releases that generate fires have localized effects.

The failure rates leading to loss of containment in gas transmission systems are very low, particularly for commercial piping and equipment such as valves and blowers.

However, the effect of human failures can be significant, as key contributors to loss of containment, either at the design phase of the system, or through poor training and poor procedural practice. It is vital that these human factors be expressly considered and managed within a facility to minimize the hazard potential.

There are some larger bio-gas releases from the CALs that could, under certain restrictive circumstances, have effect distances out to 50m. One event of this nature at Rivalea was examined by the authors. This type of event might have some implications for facilities located close to other operations or land uses. In most cases the released bio-gas is buoyant and simply disperses into the atmosphere. In the case of CALs, failure rates are low, and the subsequent risk is low provided systems are regularly maintained and upgraded over time. This is particularly related to overpressure control, and the ability to effectively handle overpressure situations.

The adoption of standard hazardous areas classification zones around CALs should be closely examined in the light of the Rivalea incident to assess their applicability.

The growing use of bio-gas for generation of electricity on-site has led to the installation of generator sets, usually installed in enclosed structures for the purpose of noise control and security reasons. This poses a unique risk of explosion of released gas within the enclosure, and amplification of blast pressure in comparison to open structures.

However, the use of ventilation systems, interlocks and gas detection mean that initial events can often not propagate to an explosive situation. Even so, it is worthwhile considering the use of open structures to avoid explosive overpressures if systems do fail.

Other small events are clearly possible, but again the effects are small and localized to the operation. It is however vital that propagation of events is promptly addressed, as escalation could generate serious outcomes on the site.

5.2 Assessment of the risks

5.2.1 Criteria for risk assessment

There are formal criteria used to assess hazardous installations that are based on the NSW Department of Planning & Infrastructure "Hazardous Industry Planning Advisory Paper No. 4" (DoPI, 2011).

These cover both fatality and injury criteria. They are given in Tables 8 and 9.

Table 11 Risk criteria for location specific individual fatality risks

LAND USE CATEGORY	RISK (PER PERSON PER YEAR)
Hospitals, schools	< 0.5 x 10 ⁻⁶
Residential areas	< 1 x 10 ⁻⁶
Active open space (sports areas)	< 10 x 10 ⁻⁶
Industrial sites	< 50 x 10 ⁻⁶

Table 12 Risk Criteria - Injury Levels

CATEGORY	RISK (PER YEAR)
Radiation	
4.7 kW/m ² , residential	< 50 x 10 ⁻⁶
23 kW/m ² , hazardous site	< 50 x 10 ⁻⁶
Overpressure	
7 kPa, residential	< 50 x 10 ⁻⁶
14 kPa, hazardous site	< 50 x 10 ⁻⁶
Toxic gas exposure	
Toxic exposure in residential areas not to exceed level producing serious injury to the most sensitive.	< 10 x 10 ⁻⁶
Toxic exposure in residential areas not to exceed level producing acute responses (irritation, coughing) to the most sensitive.	< 50 x 10 ⁻⁶

5.3 Semi-quantitative risks

The risk criteria in Tables 9 and 10 show just how low are the imposed risk levels required from industrial operations on sensitive land uses.

In this study, quantification has only be done for the consequences from loss of containment events within the system. In particular, the consequence levels for fire radiation and explosion overpressure have been used in making judgements about the impacts of hazards.

No quantitative consideration has been given to frequency of events that lead to potential impacts. Quantification is justified when the impacts can be significant and the designs are well defined.

In this study, the consequence estimates show that there is virtually no potential for major off-site impacts, and hence the risks beyond the boundary are negligible, given the siting of these operations.

However, there are potentially more serious impacts on-site in the case of large releases of gas from CALs, and the possibility of explosion impacts from enclosed space ignition of bio-gas in generator set installations. Both situations have various levels of control and mitigation in place, particularly in relation to enclosed generator sets. Multiple failures can occur in gas detection and ventilation systems that permit explosive atmospheres to form within these facilities. Physical location of the facility on the site is important to mitigate possible impacts from explosions.

Application of inherently safer design practice can also help bring risks to as low as reasonably practicable. That should be the aim of all designs and operations around bio-gas production and use.

5.4 Hydrogen sulphide impact risks

Hydrogen sulphide is a toxic gas. As such it can cause a range of physiological responses from simple annoyance to permanent injury and onto death.

There are a number of approaches to deal with the impacts of toxic gases. These include fatality estimates, and also several concentration levels normally applied for off-site emergency response. The next 2 sections deal with these approaches.

5.4.1 Fatality levels

The application of probit functions³ that describe dose-response relationships. These are often used for estimating the percentage fatality of an exposed population. A commonly used probit for H₂S is given by VROM (2005b) as:

$$Pr = -11.5 + \ln(C1.9.t)$$

where:

t = exposure time in minutes

C = gas concentration (mg/m³)

Using this probit, the concentration level for different exposure times that leads to a 1% fatality is shown in Table

³ Probit = probability unit: a common form of representing toxic dose-response data. The probit value goes from 2 (0% impact) to 8 (100% impact) with a mean at 5 (50% impact) and is sigmoidal in shape.

Table 13 1% fatality concentration for different exposure times to H₂S

EXPOSURE TIME (MINS)	H ₂ S CONCENTRATION FOR 1% FATALITY	
	MG/M3	PPMV
5	743	525
10	516	365
30	289	204
60	200	141

As can be seen in Table 13, short term exposures of 5 to 10 minutes have quite high H₂S concentration. Even so, longer term exposures which might be related to off-site situations, are still above 100ppmv.

5.4.2 Emergency response levels

There are two main emergency response level approaches:

1. Emergency Response Planning Guidelines (ERPG) levels
2. Acute Exposure Guideline Levels (AEGs)

These are primarily used for exposures of the general public to accidental releases of toxic substances. They can be very helpful in land use planning circumstances as well as emergency response to accidental releases.

There are three ERPG levels⁴ designated for H₂S:

ERPG-1: 0.1 ppm

ERPG-2: 30 ppm

ERPG-3: 76 ppm

ERPGs are for 1 hour exposure. Their definitions are:

ERPG-1 is the maximum airborne concentration below which it is believed that nearly all individuals could be exposed for up to 1 hr without experiencing other than mild transient adverse health effects or perceiving a clearly defined, objectionable odor.

ERPG-2 is the maximum airborne concentration below which it is believed that nearly all individuals could be exposed for up to 1 hr without experiencing or developing irreversible or other serious health effects or symptoms which could impair an individual's ability to take protective action.

ERPG-3 is the maximum airborne concentration below which it is believed that nearly all individuals could be exposed for up to 1 hour without experiencing or developing life-threatening health effects.

⁴ See <http://www.aiha.org/>

An alternative approach that takes into account exposure time is given by the AEGLs⁵. These are given for H₂S as:

Table 14 Acute Exposure Guideline Levels for Hydrogen Sulphide

LEVEL	10 MINS	30 MINS	60 MINS	4 HOURS	8 HOURS
AEGL-1	0.75	0.6	0.51	0.36	0.33
AEGL-2	41	32	27	20	17
AEGL-3	76	59	50	37	31

The definitions are:

AEGL-1 is the airborne concentration, expressed as parts per million or milligrams per cubic meter (ppm or mg/m³) of a substance above which it is predicted that the general population, including susceptible individuals, could experience notable discomfort, irritation, or certain asymptomatic nonsensory effects. However, the effects are not disabling and are transient and reversible upon cessation of exposure.

AEGL-2 is the airborne concentration (expressed as ppm or mg/m³) of a substance above which it is predicted that the general population, including susceptible individuals, could experience irreversible or other serious, long-lasting adverse health effects or an impaired ability to escape.

AEGL-3 is the airborne concentration (expressed as ppm or mg/m³) of a substance above which it is predicted that the general population, including susceptible individuals, could experience life-threatening health effects or death.

Significance:

1. Small 200mm diameter CAL H₂S releases during day-time and night-time periods at an upper concentration level of 0.2% (2000 ppmv) do not seem to constitute a major problem.
2. Small, 200mm diameter CAL H₂S releases at 5% concentration (50000 ppmv) during night conditions could have significant impacts.
3. Large H₂S CAL releases of 1000mm diameter at 0.2% (2000 ppmv) during night conditions could in some circumstances be problematic.
1. Large H₂S CAL releases of 1000mm diameter at 5% (50000 ppmv) would be of major concern during both day and night periods.
2. Bio-gas transmission releases of 100mm diameter at 0.2% H₂S will not have significant impacts for day-time conditions.
3. Bio-gas transmission releases of 100mm diameter at 5% H₂S will be problematic for any atmospheric condition.
4. For 200mm releases from bio-gas transmission at 0.2% (2000 ppmv) only daytime conditions do not have significant impacts, whilst 5% (50000 ppmv) releases would be problematic.

⁵ See <http://www.epa.gov/>

Implications:

1. Inherently safer design principles that eliminate potential issues should be adopted, one of these being materials selection and pipework integrity.
 2. It is crucial that where very high H₂S concentrations exist (>>0.2%) that systems are designed to ensure loss of containment is eliminated through reducing flanging and other coupling methods that can guarantee no loss of containment.
-
1. On site emergency response arrangements should specifically address toxic vapour releases, and this should be extended to off-site receptors where appropriate. Local emergency services should be informed of potential off-site toxic gas impacts, for those areas within 500m of possible releases, and particularly during night-time conditions.

6 References

Cameron, I.T., Raman R., 2005, Process System Risk Management, Elsevier.

CCPS, 1989, Guidelines for Process Equipment Reliability Data, Center for Chemical Process Safety, American Institute of Chemical Engineers, New York.

CCPS, 2000, Guidelines for Chemical Process Quantitative Risk Analysis, 2nd Edition, Center for Chemical Process Safety, AIChE, New York

DoPI, 2011, Risk Criteria for Land Use Safety Planning, HIPAP No. 4, NSW Department of Planning & Infrastructure,
<http://www.planning.nsw.gov.au/PlansforAction/Majorhazards/PlanningGuidelinesforHazardousDevelopment/tabid/168/language/en-AU/Default.aspx>, Accessed on September 12.

Lees, F.P., 2001, "Loss Prevention in the Process Industries", Butterworths-Heinemann, UK, ISBN 0-7506-1547-8.

Shell, 2006, The HGSYSTEM package, (PC based set of atmospheric dispersion models developed by Shell Research Ltd), http://www.hgsystem.com/user_guide/genintro.html

TNO, 1992, Methods for the determination of possible damage, CPR16E, Voorburg, ISBN 90-5307-052-4.

TNO, 1997, Methods for the calculation of physical effects, 3rd Edition, Voorburg, ISBN 90-12-08497-0.

UK-HSE, 2012, Failure rate and event data for use within Land Use Planning Risk Assessments, <http://www.hse.gov.uk/landuseplanning/failure-rates.pdf>

VROM, 2005a, Guideline for quantitative risk assessment, CPR18E, Ministerie van Verkeer en Waterstaat, The Netherlands.

VROM, 2005b, Methoden voor het bepalen van mogelijke schade (Methods for the determination of possible damage), CPR16E, 2nd edition, Ministerie van Verkeer en Waterstaat, The Netherlands.

Appendix A: CAL gas plume release profiles for LFL and half LFL

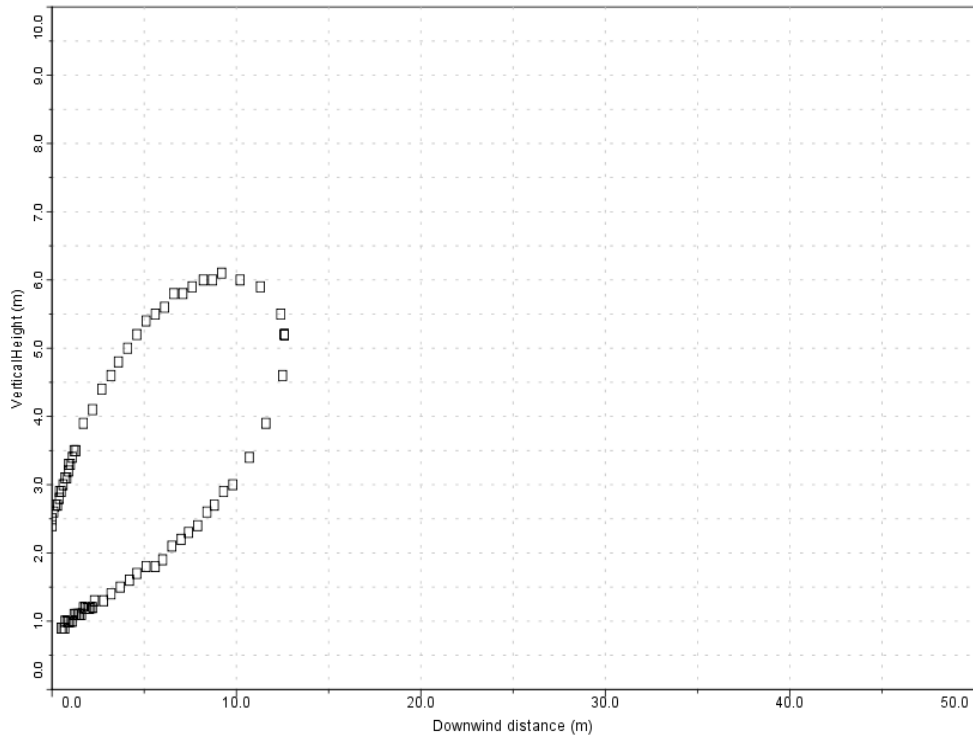

Image 1: Case 1, 50Pa.g, 1000mm aperture, 30°, D4, LFL

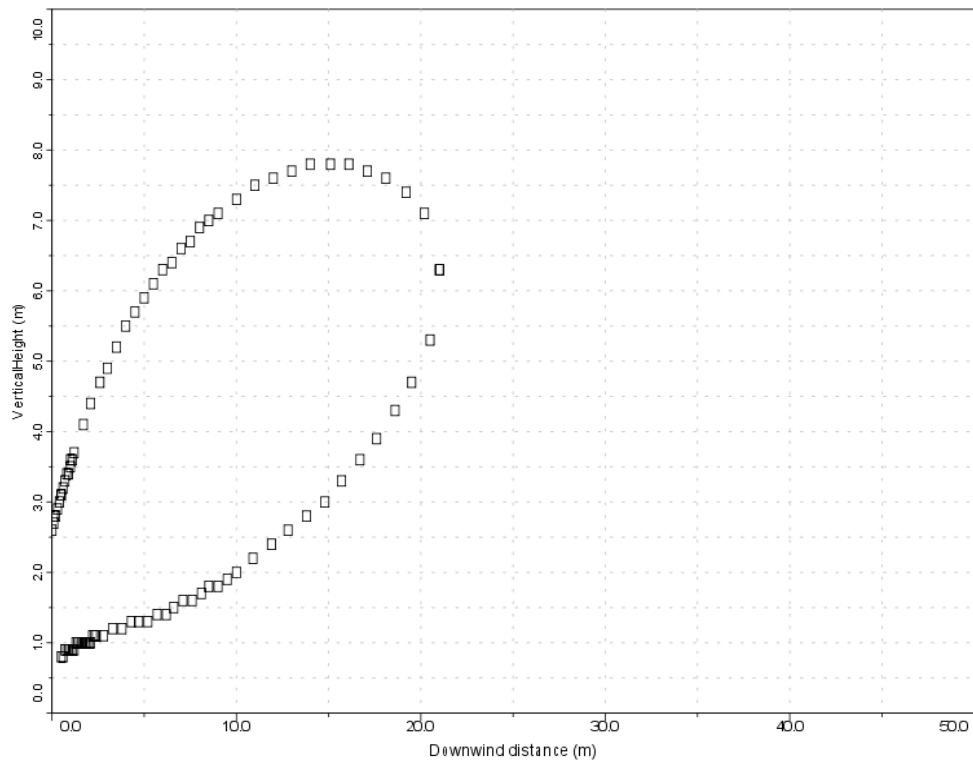

Image 2 Case 1, 50Pa.g, 1000mm aperture, 30°, D4, half LFL

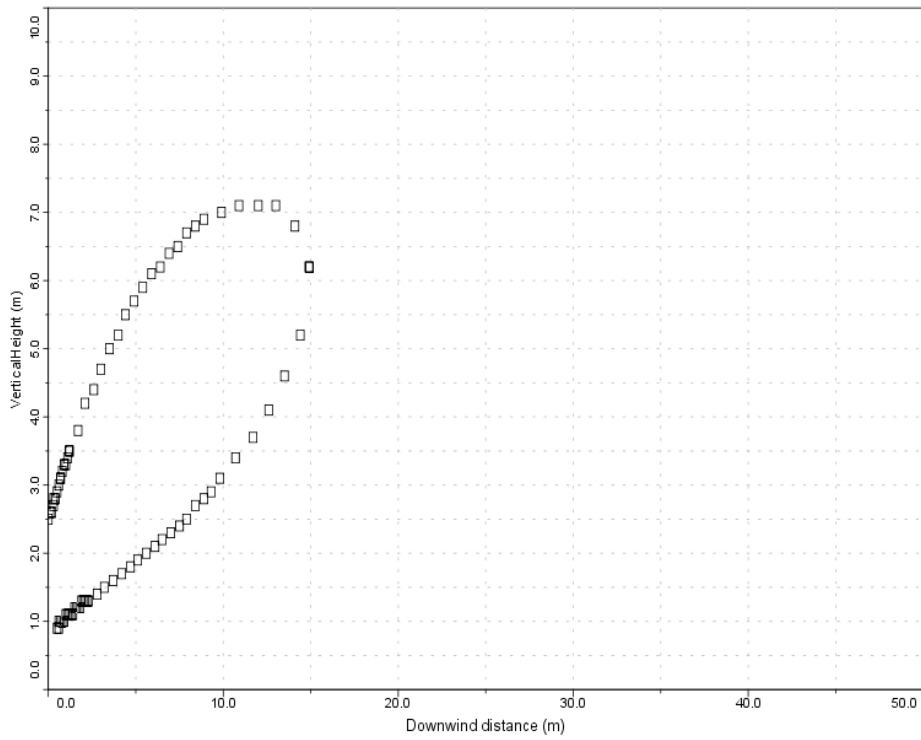

Image 3 Case 2, 100Pa.g, 1000mm aperture, 30°, D4, LFL

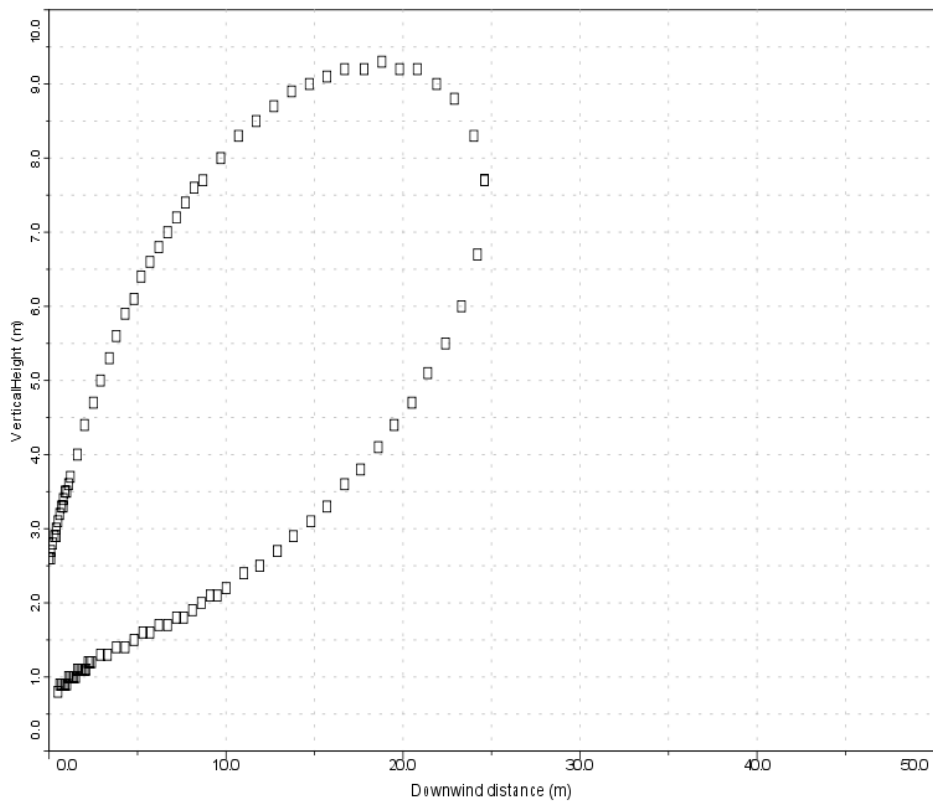

Image 4 Case 2, 100Pa.g, 1000mm aperture, 30°, D4, half LFL

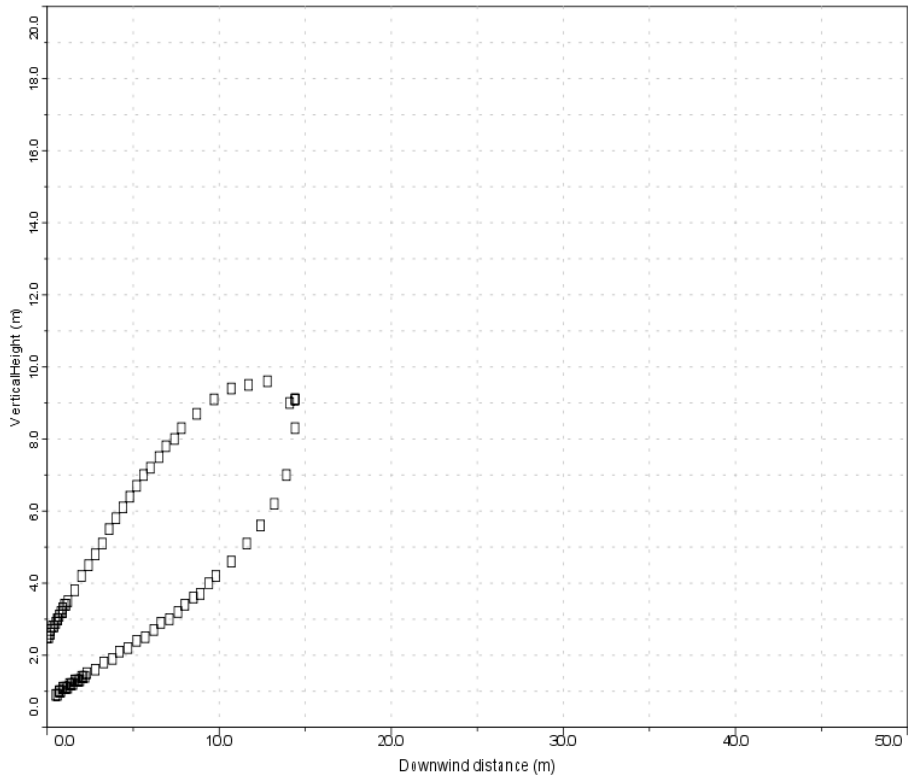

Image 5 Case 3, 100Pa.g, 1000mm aperture, 30°, B2, LFL

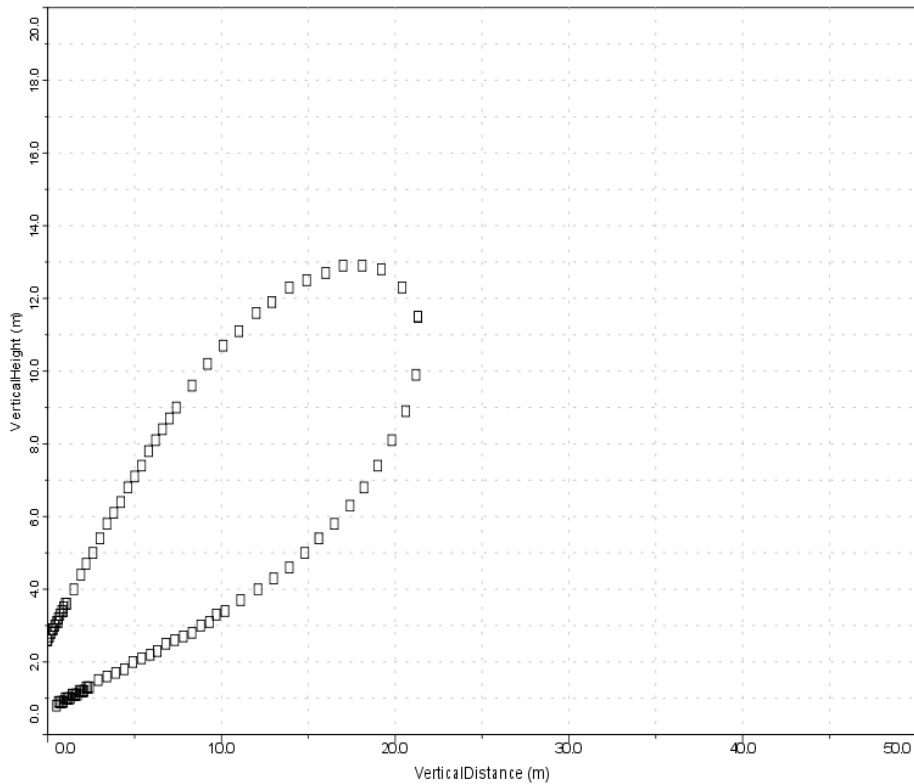

Image 6 Case 3, 100Pa.g, 1000mm aperture, 30°, B2, half LFL

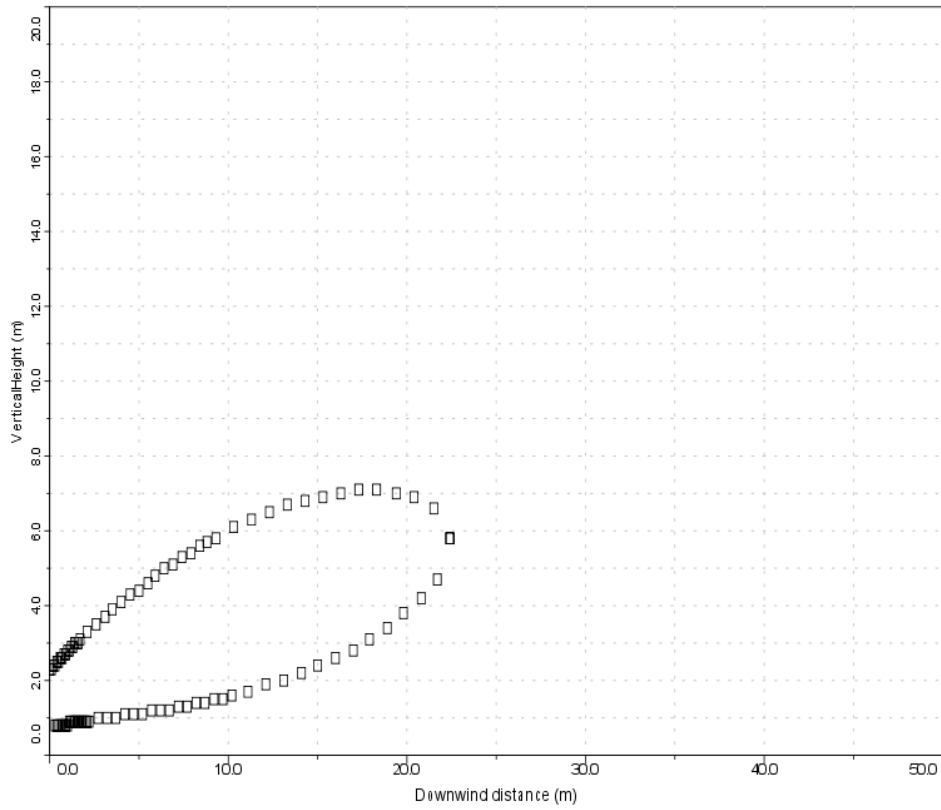

Image 7 Case 4, 200Pa.g, 1000mm aperture, 15°, D4, LFL (Rivalea test)

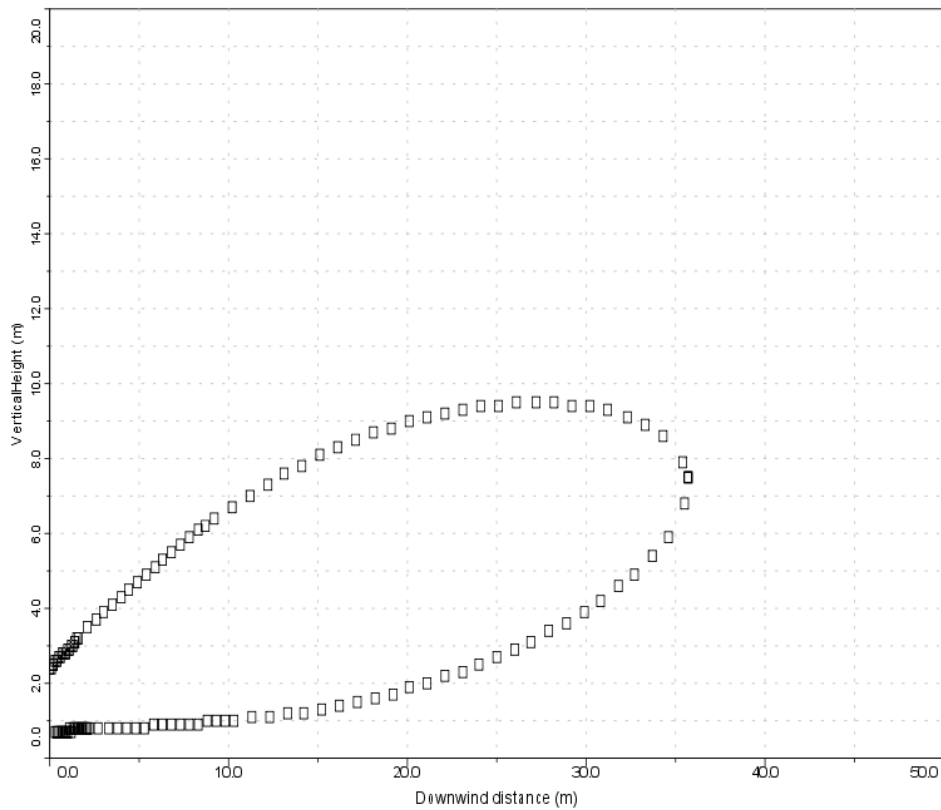

Image 8 Case 4, 200Pa.g, 1000mm aperture, 15°, D4, half LFL (Rivalea test)

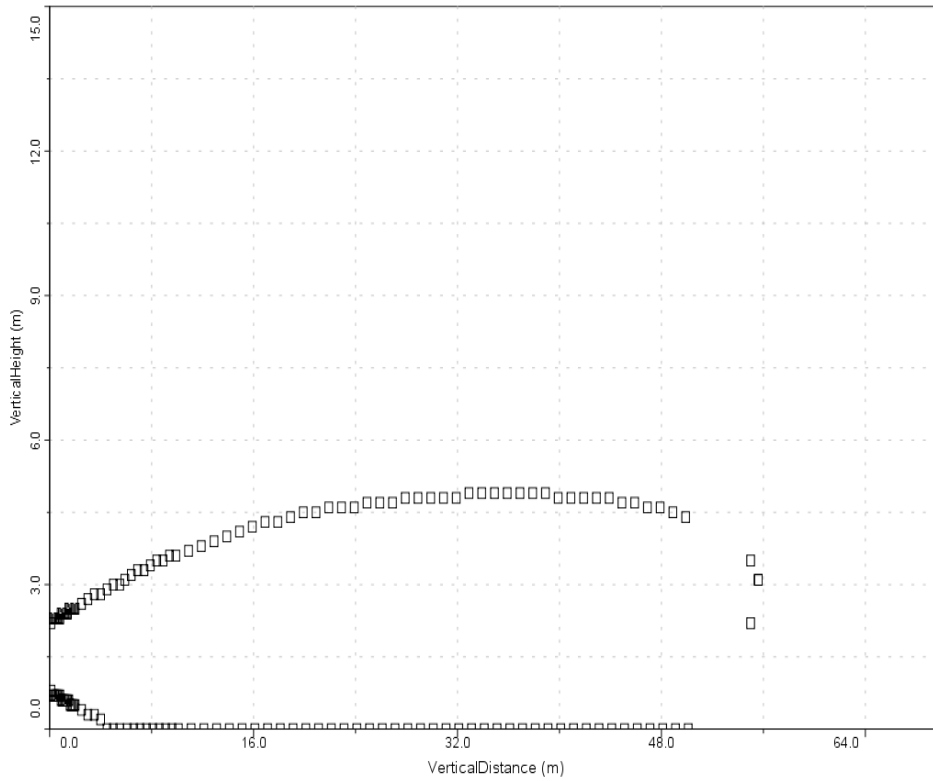

Image 9 Case 4, 200Pa.g, 1000mm aperture, 0°, D4, LFL (Rivalea test)

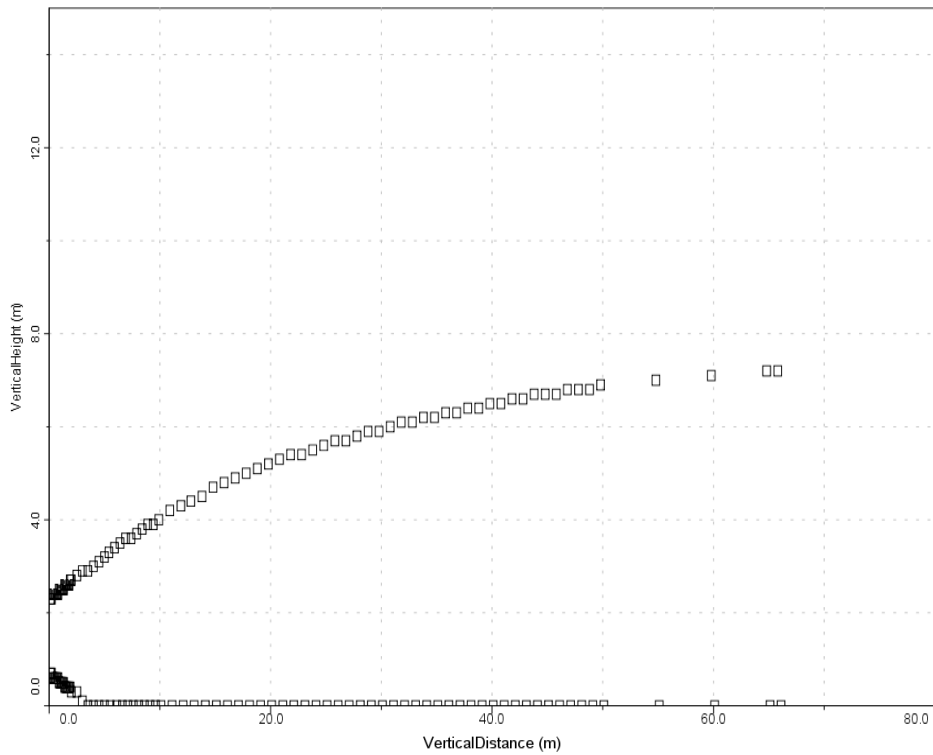

Image 10 Case 4, 200Pa.g, 1000mm aperture, 0°, D4, half LFL (Rivalea test)

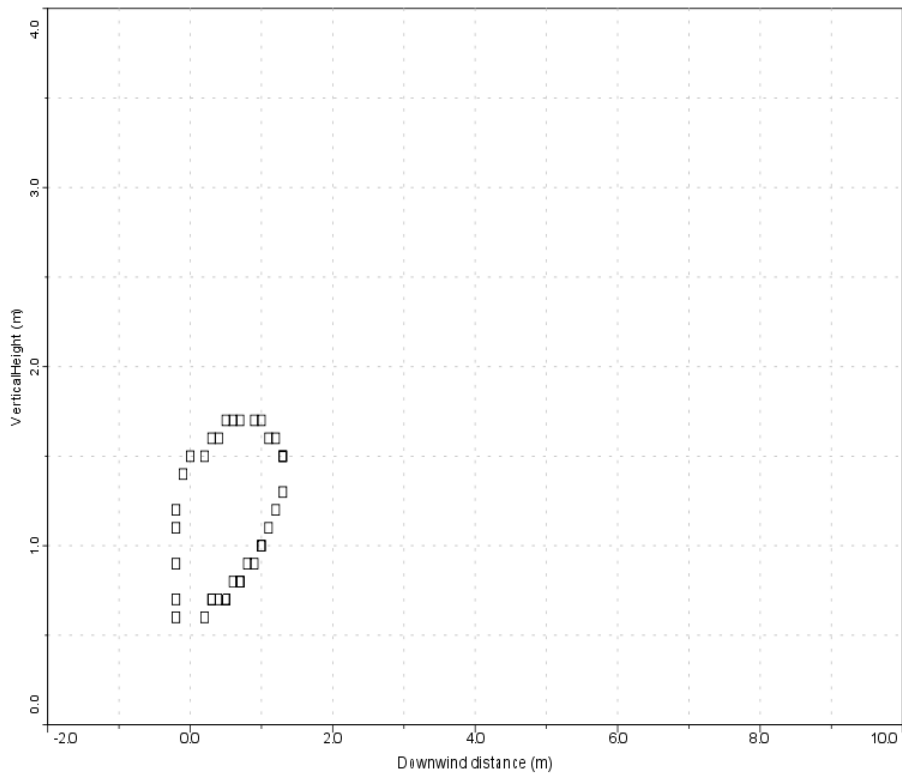

Image 11 Case 5, 50Pa.g, 200mm aperture, 90°, D4, LFL

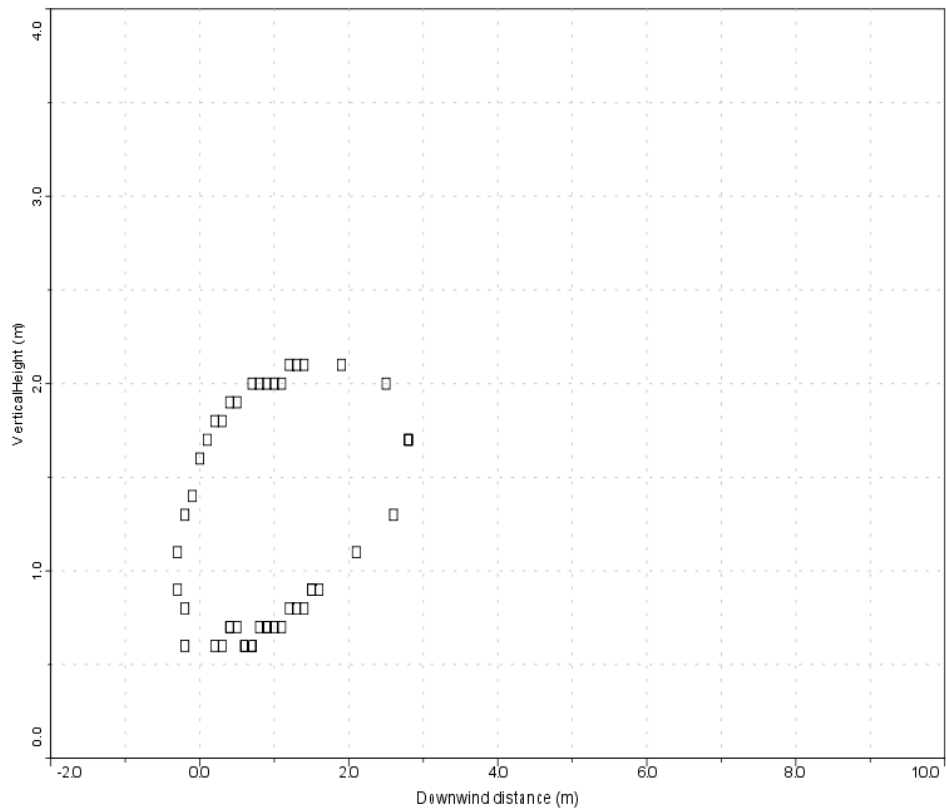

Image 12 Case 5, 50Pa.g, 200mm aperture, 90°, D4, half LFL

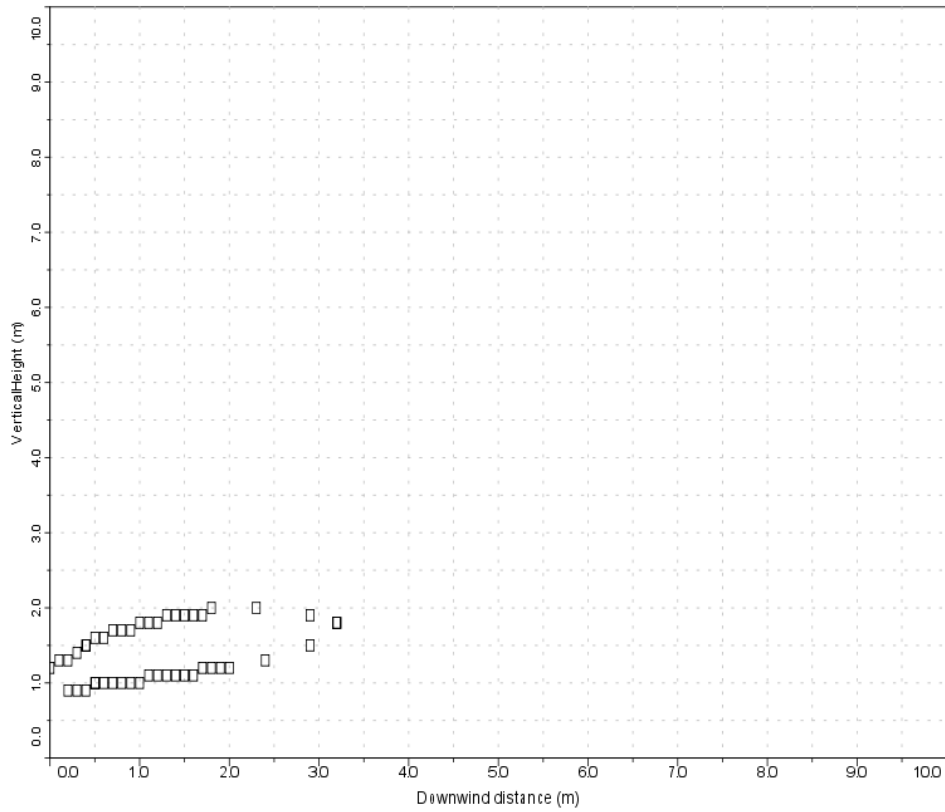

Image 13 Case 5, 50Pa.g, 200mm aperture, 30°, D4, LFL

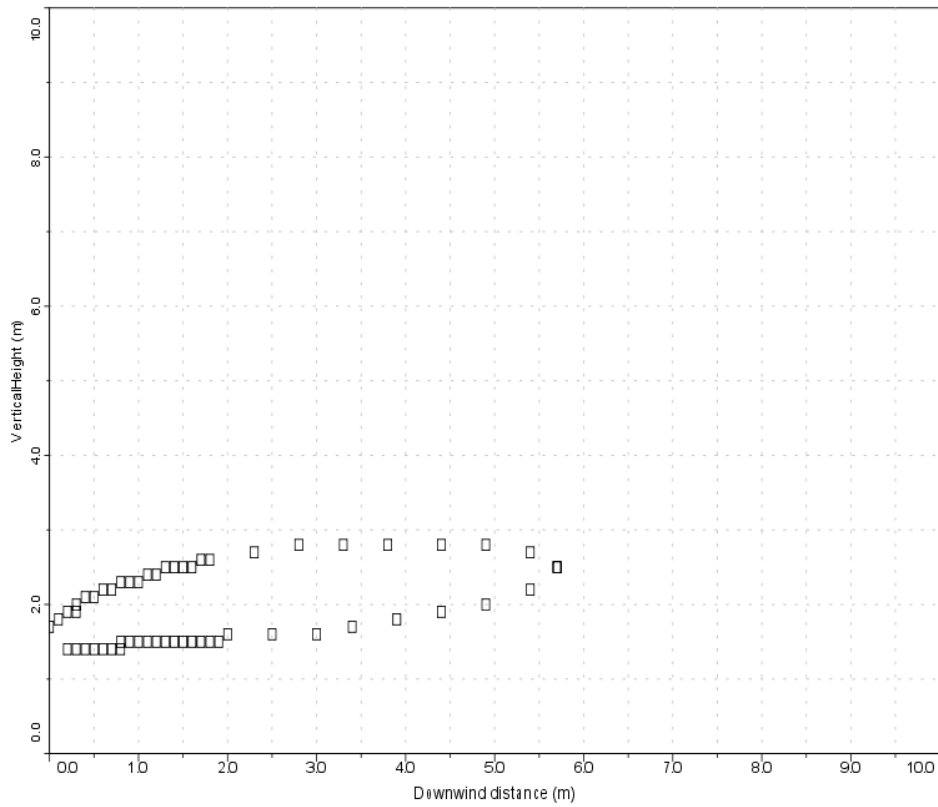

Image 14 Case 5, 50Pa.g, 200mm aperture, 30°, D4, half LFL

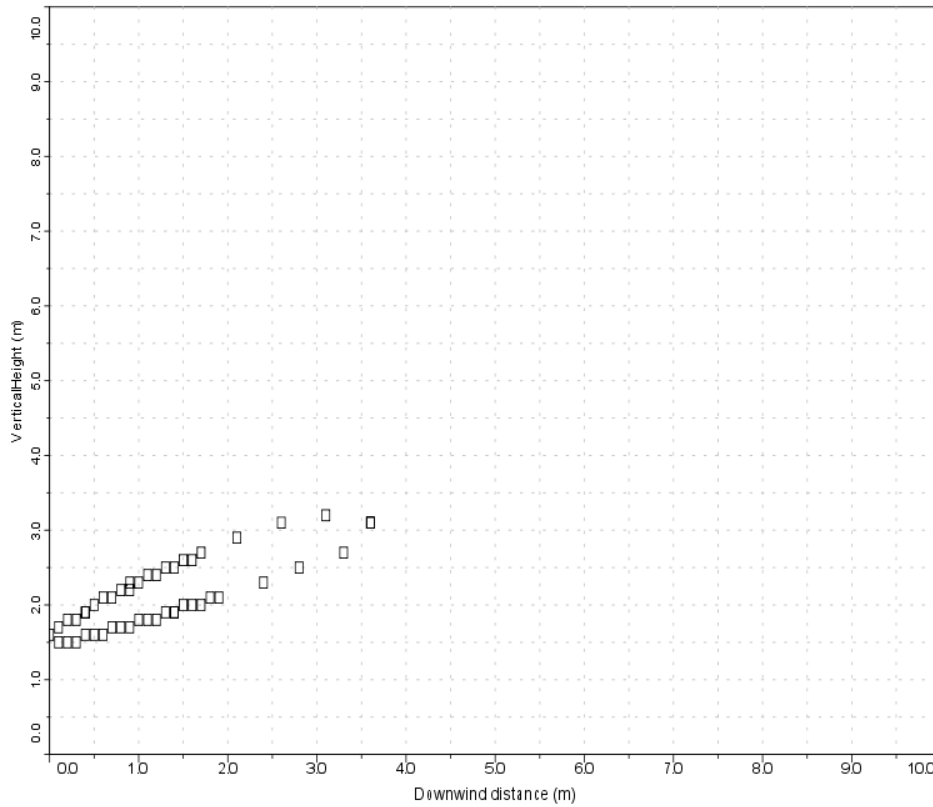

Image 15 Case 5, 4kPa.g, 100mm aperture, 30°, D4, LFL

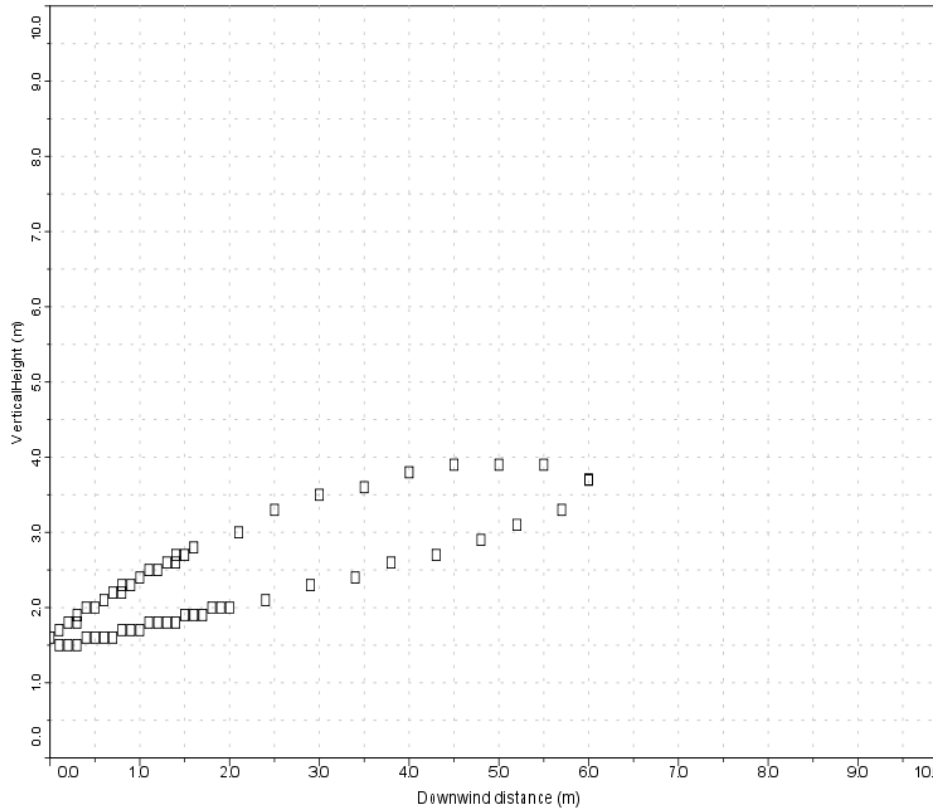

Image 16 Case 5, 4kPa.g, 100mm aperture, 30°, D4, half LFL

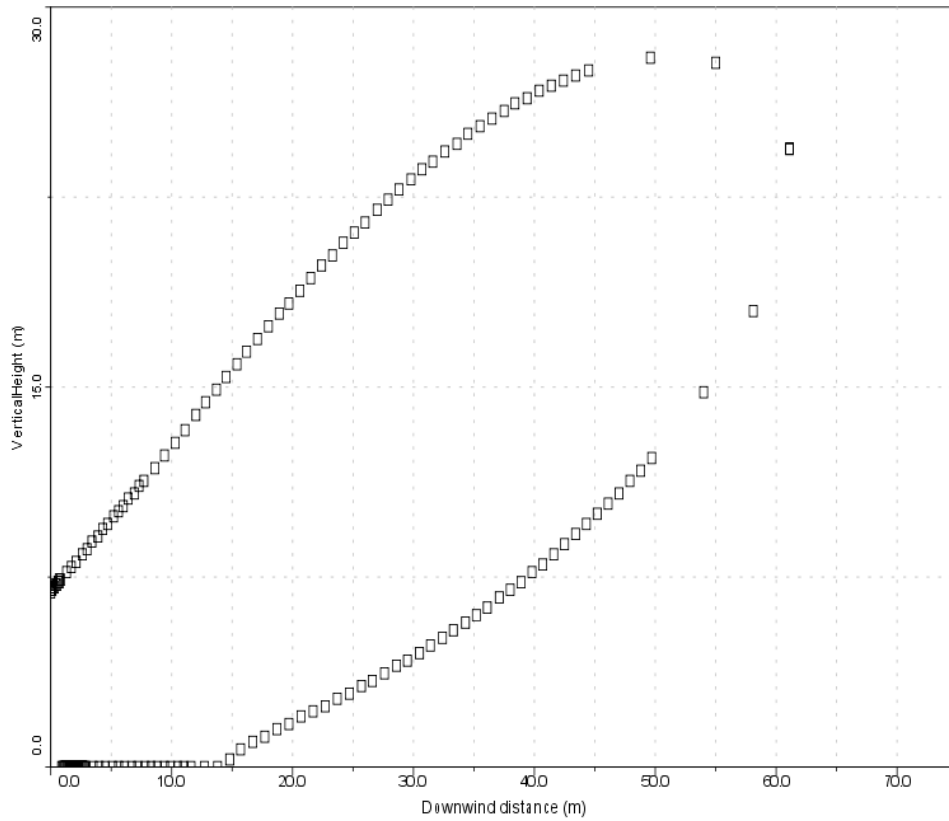

Image 17 Case 6, 100Pa.g, 5000mm aperture, 15°, D4, LFL

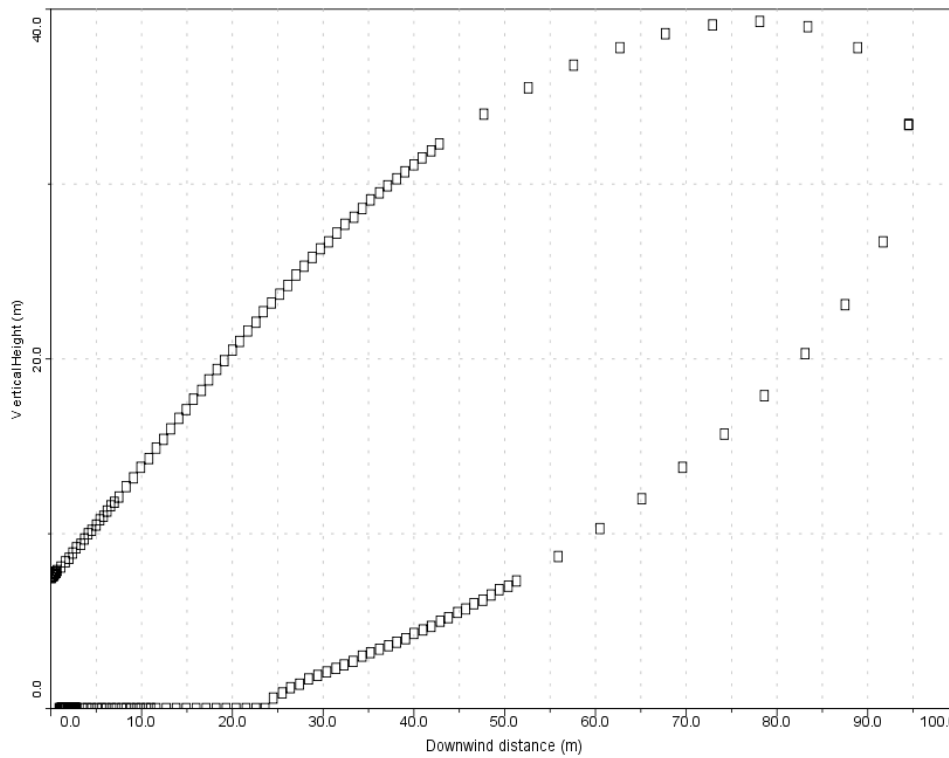

Image 18 Case 6, 100Pa.g, 5000mm aperture, 15°, D4, half LFL

Appendix B: Daesim Risk Assessor Software System

Overview

Daesim Risk Assessor is an integrated risk analysis tool for application to hazardous installations and operations. The system provides the user with facilities to carry out impact analysis, detailed event consequence calculations, construction of incidents from events and vulnerability models, as well as the construction of scenarios that locate incidents on a site plan with the purpose of generating consequence overlays and risk contours.

The range of events available consists of liquid and gas releases, pool formation, fires, explosions and gas dispersion. Sensitivity studies can also be carried out to understand the change in output predictions as a function of input data or model parameter variations. A thermo-physical database of properties provides key data to the event models. Figure 1 shows the various system windows for the definition of incidents, the visualization of consequences and the generation of risk contours.

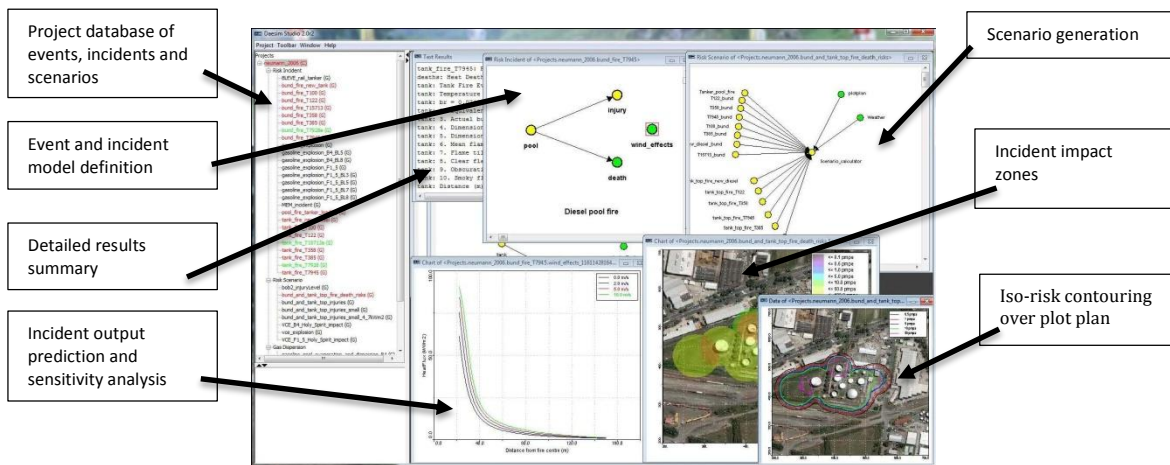

Figure A Overview of functionality and user interface

Risk Assessor also has a client-server architecture that facilitates group work from a central database of documents and local messaging between users.

User interaction:

Risk Assessor provides facilities to interactivity build incidents from events using a graphical interface where the events and linkages can be defined, and then saved to a project database. All event models such as pool fires, warehouse fires, explosions and gas releases are fully configurable. Scenarios can be built to generate iso-risk contours on plot plans or to give impact zones for specific effect levels such as thermal radiation or explosion overpressure. By defining population densities around a particular site it is possible to generate societal risk estimates in the form of F-N curves.

System logs give access to all the computations that are done within Risk Assessor. It is possible to archive individual events and incidents for re-use, as well as whole projects. This is done through generating XML output that is fully readable.

Event and incident models:

Event models are built from well-known industry sources such as the UK Health and Safety Executive, The Netherlands industrial research organization TNO and other well respected references or research works. Events and incidents, which are a sequence of linked events, can be investigated for uncertainty in input parameters such as emissive power of the flame or carbon to hydrogen ratio of the fuel. Event models can also be combined with vulnerability models, typically in the form of probability unit models (Probits) to generate impacts on vulnerable resources such as people, plant or environment. Shell’s heavy gas model, HG-System is built into the software.

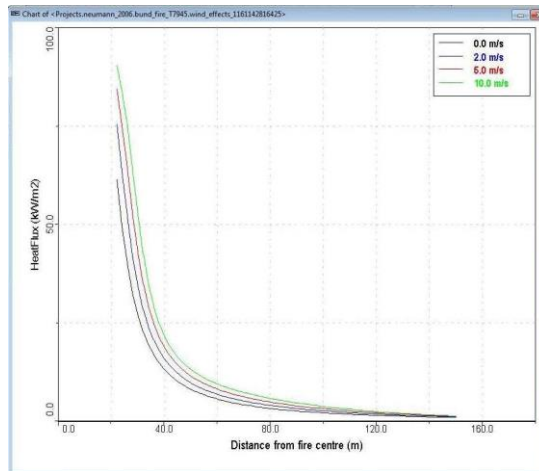

Figure B Testing the pool fire heat flux vs. wind speed

Other features:

Complex scenarios can be built from combining all relevant site incidents, coupled with generic frequency data or site specific data to generate a range of risk representations, which include physical impact maps or iso-risk contours. Frequency data can also be supplied through linked fault trees or events trees.

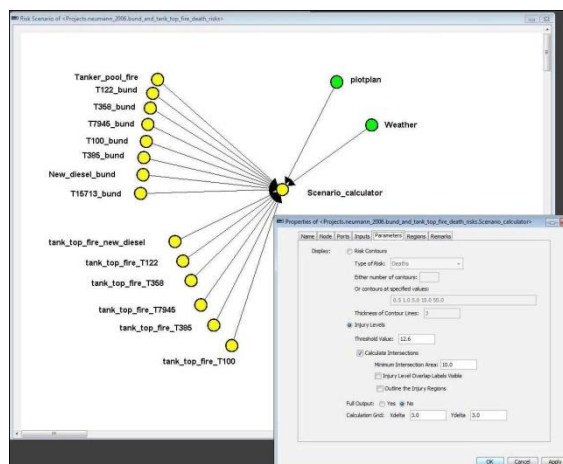

Figure C Building a scenario from linked incidents

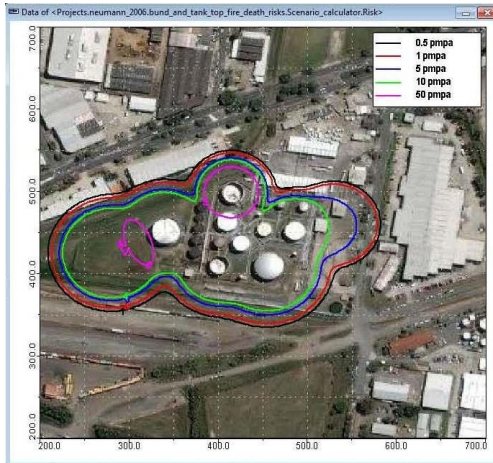

Figure D Injury level impact zones from fires (per million per annum)

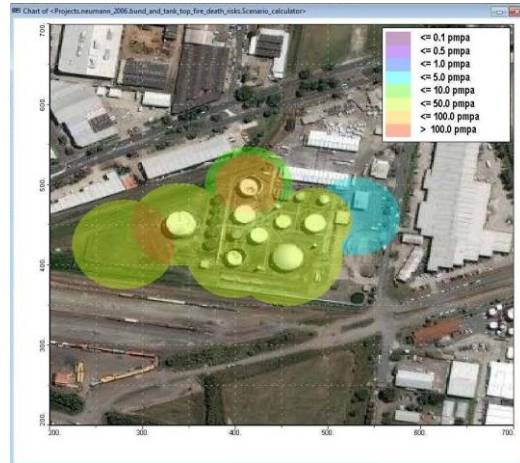

Figure E Iso-risk contours for individual fatality (per million per annum)

The system provides a flexible analysis environment and an ability to understand the risk analysis steps through generated logs and results files. Sensitivity of outcomes to uncertainties in input parameters provides improved risk insights and important decision making information.

Risk Assessor has been used for many industrial applications as well as for Major Hazard Facility (MHF) assessments for over 12 years.