

ENHANCED ENERGY RECOVERY IN AUSTRALIAN INDUSTRY THROUGH ANAEROBIC CO-DIGESTION: FULL SCALE VALIDATION

Project Report Reference: 2014-1073

Date: 28 June 2018

Project Description

The primary focus of the project is to improve the economics of biogas projects by maximizing renewable energy recovery (and revenue) from anaerobic digestion infrastructure. Co-digestion involves the simultaneous anaerobic digestion of two or more wastes. At a Red Meat Processor (RMP), wastes from other industries might be combined with RMP wastewater for covered pond treatment; or paunch solid waste for in-vessel digester treatment to boost methane production. Excluding crop and animal waste, Australia generates over 14 million ton of organic waste per year (Figure 1) and approximately 50% is currently disposed to landfill.

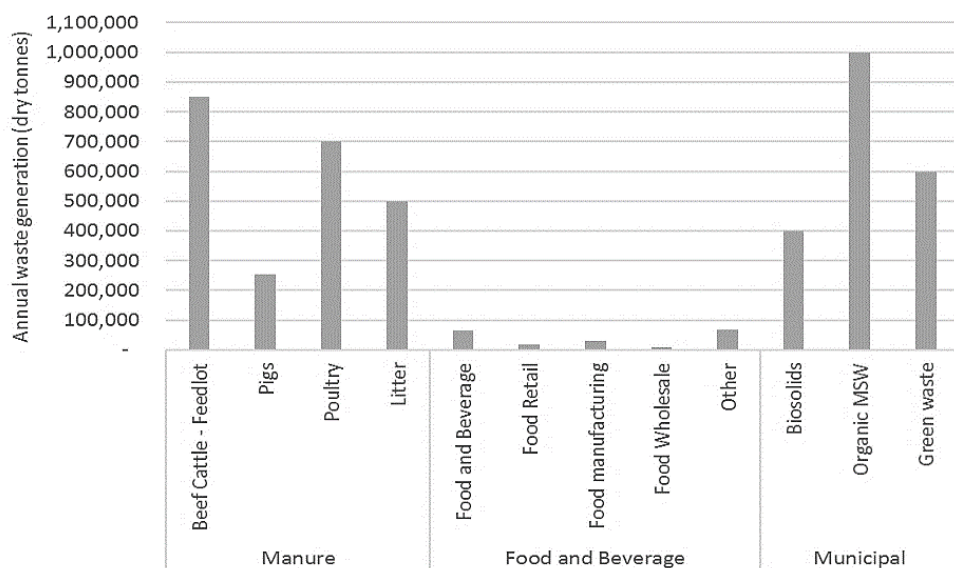

Figure1: Estimated Australian organic waste production for selected industries.

Project Content

During this project Paunch Solids Waste (i.e. Figure 1) was exported to a piggery and co-digested with piggery manure in a full-scale 2-stage in vessel anaerobic digester. The configuration of the Trade Waste co-digestion facility is shown in Figure 1. The digesters process 120,000 L of screened piggery manure each day and receive 10-30 tonnes of dewatered paunch. Paunch was loaded throughout the day from a holding area.

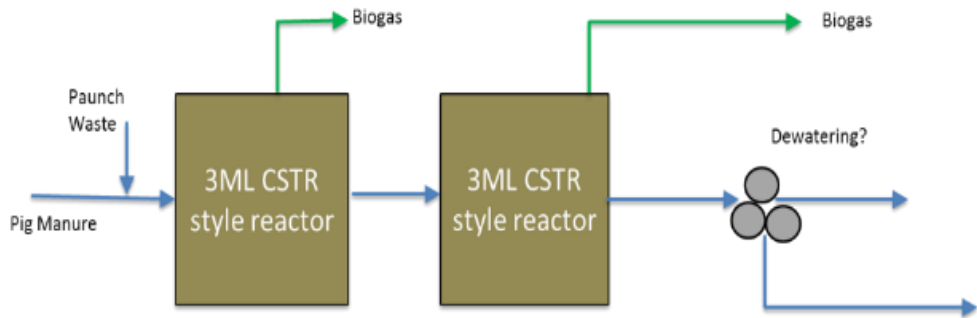

Figure 1: Configuration of Trade Waste Co-digestion Facility.

The mass of paunch solid waste added during the trial was variable, but generally represented an additional 60-100% feed on a total solids basis. Example results are shown in Figure 3 and demonstrate improvements in methane production ranging from 80% to 100%, depending on the mass of paunch added. Importantly, the results are consistent with small scale laboratory results and model predictions. Methane yields achieved from paunch co-substrate addition were estimated at 200 to 250 L.kgVS⁻¹ added, this yield is also consistent with laboratory testing and demonstrate complete recovery of available methane, this confirms that the equipment operated within process limits and that co-digestion was successful.

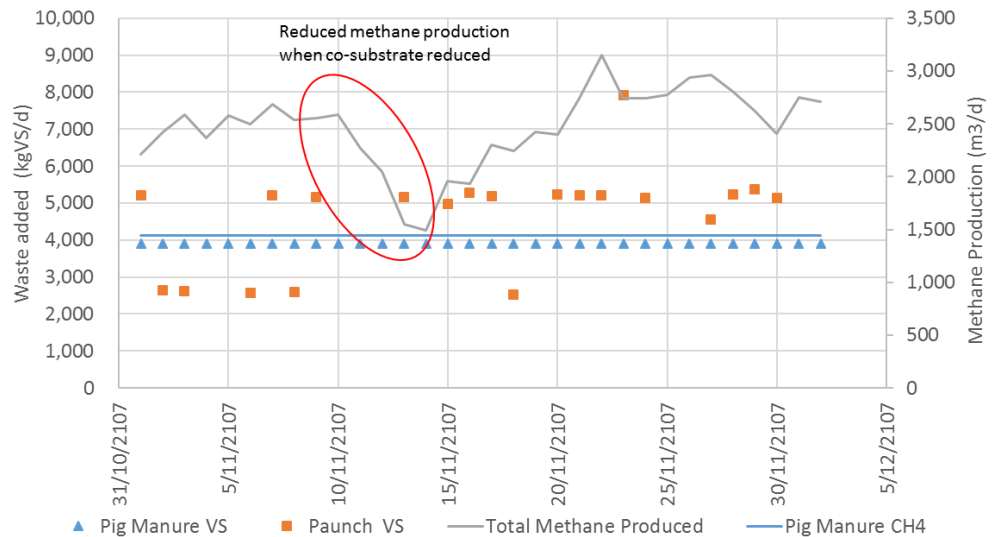

Figure 3: Results from full-scale co-digestion of pig manure and solid cattle paunch. Blue marker shows pig manure added (based on average data), orange marker shows paunch added based on daily measurements. Grey line shows CH₄ recorded in the trial, the blue line shows the CH₄ predicted if co-digestion was not applied and only pig manure was treated.

Project Outcome

- The Project conducted extensive laboratory testing to predict anaerobic digester performance of over 30 industry wastes, including paunch solid waste, DAF sludge, red screening, wastewater sludge and manure from red meat processers
- The project developed a co-digestion tool, implemented in Microsoft Excel, to predict the performance of full-scale co-digestion processes. The tool is based around first-order continuous stir tank reactor (CSTR) models that incorporate biological and kinetic parameters from laboratory testing.
- During the full-scale validation, paunch solid waste was exported to a piggery for co-digestion. Using co-digestion, process loading increased 60-100% and methane production from the process increase between 80-100%.
- Methane production during full-scale validation was consistent with laboratory testing and model predictions. Indicating that co-digestion was both successful and performance was predictable.

Benefit for Industry

Australian industries, including RMP already operate a number of biogas technologies with >100 full-scale installations in Australia representing >\$100 million in infrastructure. Much of this existing infrastructure is underutilised. Co-digestion can enhance biogas production from this existing infrastructure by >150%. Co-digestion economics are highly variable ranging from \$160/T revenue to >\$30/T cost. Therefore, correct mixture selection is critical.

Waste selection must be compatible with existing infrastructure and dosing must stay within process limits to maintain stability. This project demonstrates that co-digestion performance at full-scale is predictable and tangible benefits can be achieved. Well-designed co-digestion can substantially improve the economics of anaerobic digestion and improve RMP adoption.

USEFUL RESOURCES

Project final Report:

Snapshot Fundamental Knowledge:

Snapshot Industry Co-digestion:

Co-digestion Prediction Tool:



Disclaimer:

The information contained within this publication has been prepared by a third party commissioned by Australian Meat Processor Corporation Ltd (AMPC). It does not necessarily reflect the opinion or position of AMPC. Care is taken to ensure the accuracy of the information contained in this publication. However, AMPC cannot accept responsibility for the accuracy or completeness of the information or opinions contained in this publication, nor does it endorse or adopt the information contained in this report.

No part of this work may be reproduced, copied, published, communicated or adapted in any form or by any means (electronic or otherwise) without the express written permission of Australian Meat Processor Corporation Ltd. All rights are expressly reserved. Requests for further authorisation should be directed to the Executive Chairman, AMPC, Suite 1, Level 5, 110 Walker Street North Sydney NSW.